



Universal Wall-Mount Controller with IAQ Sensors

Inputs and Outputs

- One configurable analog input (AI1)
- One binary input (BI1)
- Two fully configurable analog outputs (2 AO)
- Two fully configurable binary outputs (2 BO)

Features

- Built-in application profiles to automatically configure the controller for the selected application.
- Up to 4 simultaneous control loops capable of controlling, in real time:
 - Humidification and Dehumidification
 - Heating and Cooling
 - CO₂ levels
 - VOC levels
- Integrated ECM fan control mode
- Displays temperature, %RH, CO₂, VOC, and setpoints
- Display or hide all the required access for user interaction
- Backlit LCD with simple icon and text-driven menus
- Selectable Fahrenheit or Celsius scale
- Precise temperature control with programmable PI function
- Independent cool and heat setpoint for No Occupancy
- Configurable proportional control band and dead band

On-board Sensors

- Temperature sensor (°C/°F)
- Humidity sensor (%RH), select models
- Carbon dioxide sensor (CO₂), select models
- VOC sensor (volatile organic compounds), select models
VOC are volatile organic chemicals (indoor air pollutants)

Network Communication (AROB only)

- BACnet[®] MS/TP or Modbus (selectable via menu)
- Select MAC address via menu or via network
- Automatic baud rate detection

BACnet MS/TP[®]

- MS/TP @ 9600, 19200, 38400, 57600 or 76800 bps
- Automatic device instance configuration
- Network service port via on-board mini USB connector

Modbus

- Modbus @ 9600, 19200, 38400, or 57600 bps
- RTU Slave, 8 bits (configurable parity and stop bits)
- Connects to any Modbus master



Built-In Application Profiles

IAQ and ECM Fan Control Applications as Easy as 1-2-3!

- STEP 1:** Enter configuration mode
- STEP 2:** Select desired profile (e.g. Conference Room)
controller automatically configures required options
- STEP 3:** Wire connections as shown below

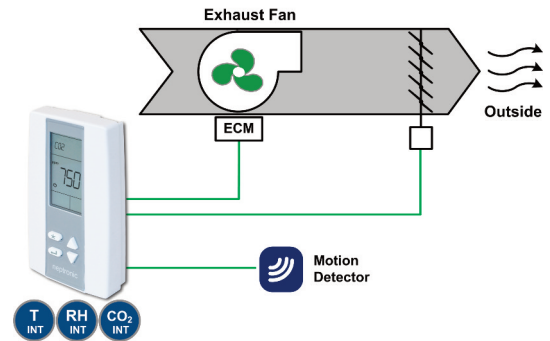

Wiring Diagram (Conference Room Application Profile)

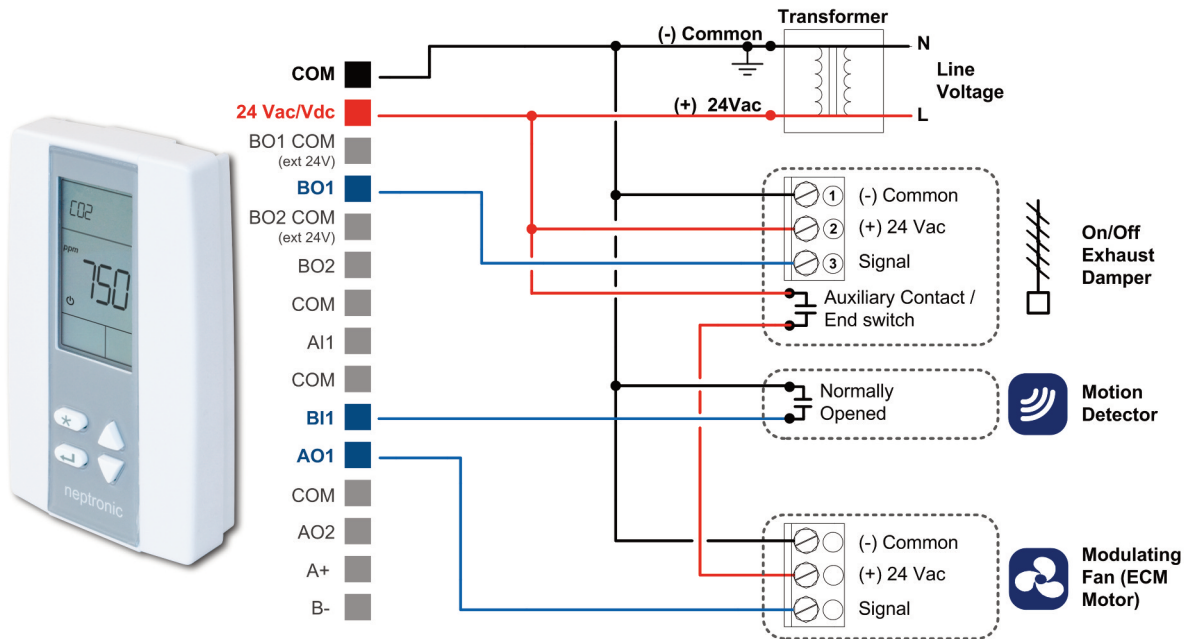

Stand-Alone Models

Model	Temp	RH	CO ₂	VOC
ARO24T	●			
ARO24TH	●	●		
ARO24TGH	●	●	●	
ARO24TGVH	●	●	●	●

Networkable Models

Model	Temp	RH	CO ₂	VOC
AROB24T	●			
AROB24TH	●	●		
AROB24TGH	●	●	●	
AROB24TGVH	●	●	●	●