

Models

Model #	Temp	RH	CO2	VOC	Networkable*
ARO24T	•				
ARO24TH	•	•			
ARO24TGH	•	•	•		
ARO24TGVH	•	•	•	•	
AROB24T	•				•
AROB24TH	•	•			•
AROB24TGH	•	•	•		•
AROB24TGVH	•	•	•	•	•

* Networkable: BACnet MS/TP or Modbus (selectable using menu)

Description

IAQ and ECM fan control applications made easy! Introducing the new ARO series universal room controller with onboard CO₂, VOC, temperature and humidity sensors, selectable application control profiles, up to 4 simultaneous control loops, and seamless control of a 0-10 Vdc ECM fan. All of this in one wall-mounted room controller.

The AROB series networkable controller operates over an RS-485 network using the BACnet MS/TP or Modbus protocol to exchange information with a Building Management System.

Features

Onboard Sensors

- Temperature sensor (°C/°F)
- Humidity sensor (%RH), select models
- VOC sensor (volatile organic compounds), select models
- Carbon dioxide sensor (CO₂), select models

Functions

- Built-in application profiles to automatically configure the controller for the selected application.
- Up to 4 simultaneous control loops capable of controlling, in real time:
 - Humidification and Dehumidification
 - Heating and Cooling
 - CO₂ levels
 - VOC levels
 - Integrated EC fan control mode
- Display or hide all the required access for user interaction
- Backlit LCD with simple icon and text-driven menus
- Selectable Fahrenheit or Celsius scale
- Precise temperature control with programmable PI function
- Independent cool and heat setpoint for No Occupancy

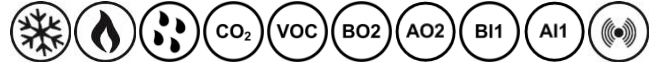

ARO Series

Network Communication

(AROB series only)

- BACnet[®] MS/TP or Modbus communication port (selectable using menu)
- Select MAC address using menu or network
- Automatic baud rate detection

BACnet[®]

- MS/TP at 9600, 19200, 38400, 57600 or 76800 bps
- Automatic device instance configuration
- Copy and broadcast configuration to other controllers
- Network service port through on-board mini USB connector

Modbus

- Modbus at 9600, 19200, 38400 or 57600 bps
- RTU Slave, 8 bits (configurable parity and stop bits)
- Connects to any Modbus master

Technical Specifications

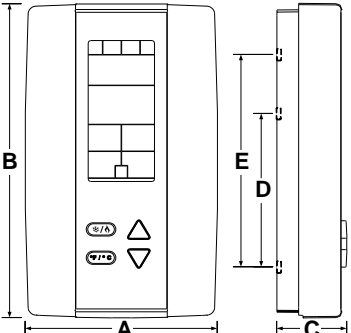
Description	ARO Series
Temperature Sensor	
Setpoint range	10°C to 40°C [50°F to 104°F]
Control accuracy	Temperature: $\pm 0.4^{\circ}\text{C}$ [0.8°F]
Display resolution	$\pm 0.1^{\circ}\text{C}$ [0.2°F]
Humidity Sensor (select models)	
Setpoint range	10 to 65%RH
Control accuracy	$\pm 3.5\%$ RH
Display resolution	0.1%
CO2 Sensor (select models)	
Operating principle	Self-calibrating, Non-Dispersive Infrared (NDIR)
Sensor range	400 to 2000 ppm
Accuracy	± 30 ppm $\pm 3\%$ of reading (Accuracy is defined after minimum 3 weeks of continuous operation)
Response time	2 minutes by 90%
VOC Sensor (select models)	
Operating principle	Self-calibrating, Non-Dispersive Infrared (NDIR)
Sensor range	0-1000 ppb isobutylene equivalent tVOCs
Response time	< 5 seconds for tVOC
Start up time	15 minutes
Other	
Inputs	1 Analog input: 0-10Vdc, Thermistor (10k Type 3) 1 Binary input: digital input (dry contact)
Outputs	2 Binary outputs (BO1 and BO2), dry contacts 24Vac, 1A max 3A in-rush 2 Analog outputs (AO1 and AO2), 0 to 10Vdc configurable
BACnet	BACnet [®] MS/TP @ 9600, 19200, 38400, 57600 or 76800 bps (B-ASC)
Modbus	Modbus RTU slave @ 9600, 19200, 38400 or 57600. Selectable parity and stop bit configuration: No parity, 2 stop bit Even parity, 1 stop bit Odd parity, 1 stop bit
Communication Connections	24 AWG twisted-shield cable (Belden 9841 or equivalent)
Electrical connection	0.8 mm ² [18 AWG] minimum
Operating temperature	0°C to 50°C [32°F to 122°F]
Storage temperature	-30°C to 50°C [-22°F to 122°F]
Relative humidity	5 to 95 % non-condensing
Enclosure protection	IP 30 (EN 60529)
Weight	120 g. [0.25 lb]
Dimensions	 <p> A = 2.85" 73mm B = 4.85" 123mm C = 1.00" 24mm D = 2.36" 60mm E = 3.27" 83mm </p>



Wiring

We strongly recommend to wire all controllers to a separate grounded transformer, and that transformer shall service only these products. This precaution prevents interference with and possible damage to incompatible equipment.



Avoid touching the VOC and CO2 sensors as this may cause incorrect readings

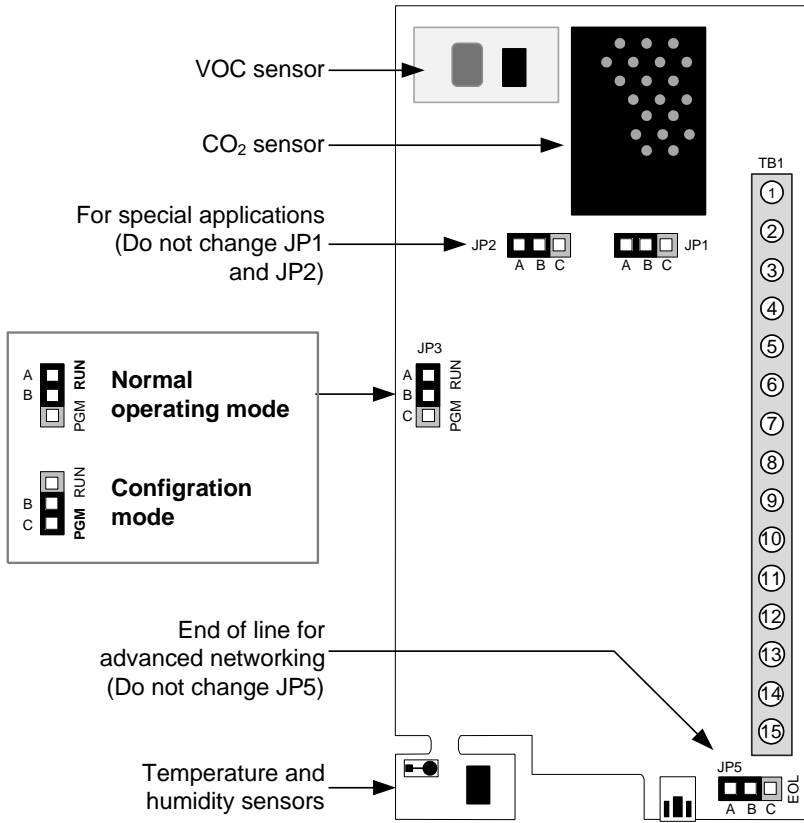

Terminal Description	Details	
1	COM	
2	24Vac / 24Vdc	
3	COM for BO1 (ext 24V)	If JP1 is set to A+B
4	Binary Output 1 (BO1)	
5	COM for BO2 (ext 24V)	If JP2 is set to A+B
6	Binary Output 2 (BO2)	
7	COM	
8	Analog Input (AI1)	
9	COM	
10	Binary Input 1 (BI1)	
11	Analog Output 1 (AO1)	
12	COM	
13	Analog Output 2 (AO2)	
14	BACnet/Modbus A+	
15	BACnet/Modbus B-	

Mounting Instructions



CAUTION: Remove power to avoid a risk of malfunction.

- Remove the captive screw that is holding the base and the front cover of the unit together.
- Lift the front cover of the unit to separate it from the base.
- Pull all wires through the holes in the base.
- Secure the base to the wall using wall anchors and screws (supplied). Make the appropriate connections.
- Mount the control module on the base and secure using the screw.

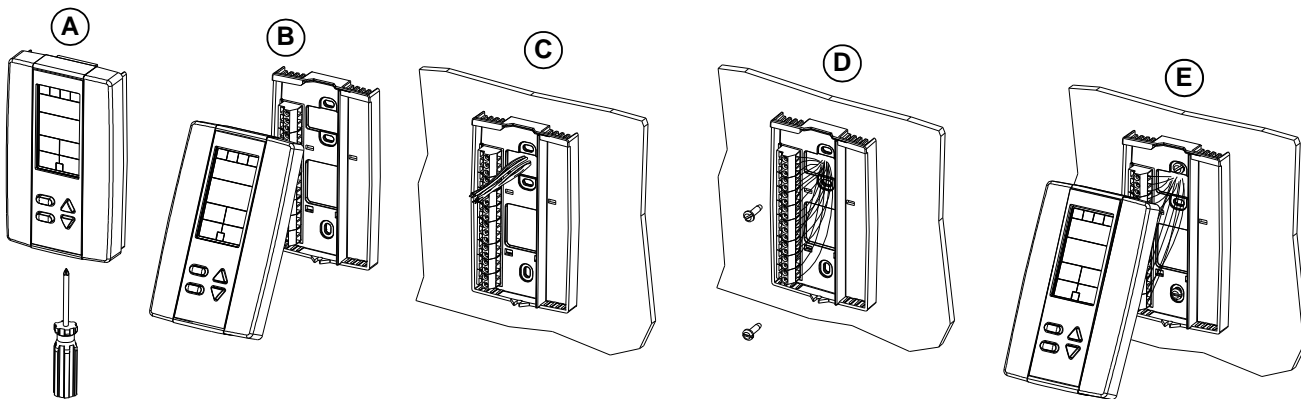

LCD Legend

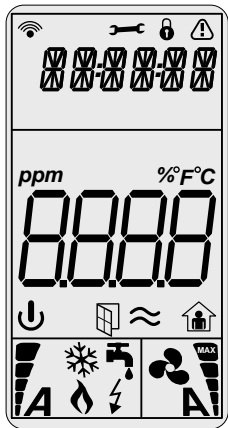

- Networked Communication
- Configuration Mode
- Alarm or Error
- System Mode (on/off)
- CO2
- VOC
- NSB mode = Normal
OCC mode = Occupied
- Cooling
- Dehumidification
- Heating
- Humidification
- Fan
- NSB mode = Night Set Back Mode
OCC mode = Unoccupied

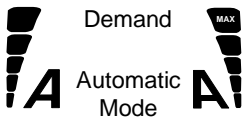

Configuration Menu

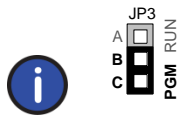

Set the Mode Selector Jumper **JP3** to the **"PGM"** mode (Programming Mode). For more information, see

Wiring on page 3. To exit, set the Jumper JP3 back to the **"RUN"** mode (Operation Mode). All changes are saved.

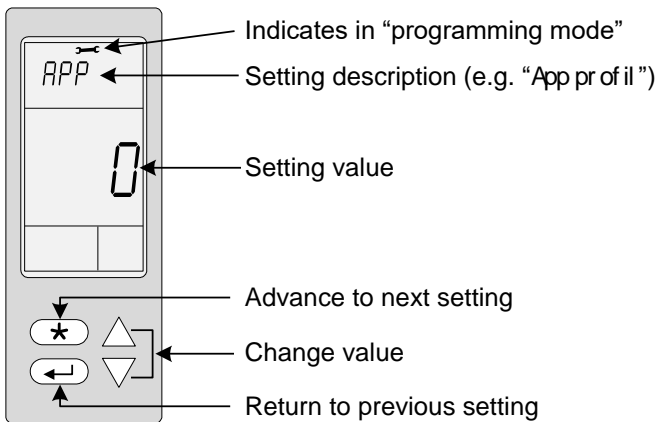

Step / Display	Description	Default	Range / Offset	Increment
1. App Profile	Built-in application profiles automatically configure the controller for the selected application.	0	0 = None; advanced manual configuration 1 = Outside Air Applications (see page 13) 2 = Conference room (see page 14)	1
2. Intrn Temp Offset	The display shows the temperature read by the temperature sensor. Adjust the offset by comparing it with a known value.	Current value	32°F to 122°F / offset: ±9°F (0°C to 50°C / offset: ±5°C)	0.2°F (0.1°C)
3. Cool Setpnt Min	The user cannot decrease the setpoint to less than this value.	50°F (10°C)	32°F to 257°F (0°C to 125°C)	0.2°F (0.1°C)
4. Cool Setpnt Max	The user cannot increase the setpoint to more than this value.	104°F (40°C)	32°F to 257°F (0°C to 125°C)	0.2°F (0.1°C)



Step / Display	Description	Default	Range / Offset	Increment
5. Cool Setpnt	Cooling setpoint.	71.6°F (22.0°C)	32°F to 257°F (see min and max value) (0°C to 125°C)	0.2°F (0.1°C)
6. Heat Setpnt Min	The user cannot decrease the setpoint to less than this value.	50°F (10°C)	32°F to 257°F (0°C to 125°C)	0.2°F (0.1°C)
7. Heat Setpnt Max	The user cannot increase the setpoint to more than this value.	104°F (40°C)	32°F to 257°F (0°C to 125°C)	0.2°F (0.1°C)
8. Heat Setpnt	Heating setpoint.	68°F (20°C)	32°F to 257°F (see min and max value) (0°C to 125°C)	0.2°F (0.1°C)
9. Temp Mode	Temperature control mode that you want to authorize to the user in operation mode.	OFF	Auto (Automatic), Cool (Cooling Only), OFF, HEAT (Heating Only)	--

Humidity Setpoints and User Control

The humidity and dehumidification settings appear only on models with the humidity sensor (see Models on page 1).

10. Humdty Offset	The display shows the relative humidity read by the humidity sensor. Adjust the offset by comparing it with a known value.	Current value	0% to 100% RH / Offset: ±5%	0.1% RH
11. Dehum setpnt Min	The user cannot decrease the setpoint to less than this value.	10% RH	0 to 100% RH	0.1% RH
12. Dehum Setpnt Max	The user cannot increase the setpoint to more than this value.	80% RH	0 to 100% RH	0.1% RH
13. Dehum setpnt	Dehumidification setpoint.	60% RH	0 to 100% RH (see min and max value)	0.1% RH
14. hum setpnt Min	The user cannot decrease the setpoint to less than this value.	10% RH	0 to 100% RH	0.1% RH
15. hum Setpnt Max	The user cannot increase the setpoint to more than this value	80% RH	0 to 100% RH	0.1% RH
16. hum setpnt	Humidification setpoint.	40% RH	0 to 100% RH (see min and max value)	0.1% RH
17. Humdty Mode	Humidification control mode that you want to authorize to the user in operation mode.	OFF	OFF, hUn (Humidity Only), Auto (Automatic), dhUn (Dehumidification Only)	--

CO2 Setpoints and User Control

The following CO2 settings appear only on models with the CO2 sensor (see Models on page 1).

18. CO2 Offset	The display shows the CO2 level read by the CO2 sensor. Adjust the offset by comparing it with a known value.	Current value	0 to 2000 PPM / Offset: ± 200 PPM	1 PPM
19. CO2 setpnt Min	The user cannot decrease the setpoint to less than this value.	400 PPM	0 to 2000 PPM	1 PPM
20. CO2Setpnt Max	The user cannot increase the setpoint to more than this value.	1500 PPM	0 to 2000 PPM	1 PPM
21. CO2 setpnt	CO2 setpoint.	600 PPM	0 to 2000 PPM (see min and max value)	1 PPM
22. CO2 Mode	Enable or disable CO2 operation mode.	OFF	ON or OFF	--

VOC Setpoints and User Control

The following VOC settings appear only on models with the VOC sensor (see Models on page 1).

23. VOC Offset	The display shows the VOC level read by the VOC sensor. Adjust the offset by comparing it with a known value.	Current value	0 to 1000 PPB / Offset: ± 100 PPB	1 PPB
24. VOC setpnt Min	The user cannot decrease the setpoint to less than this value.	0 PPB	0 to 1000 PPB	1 PPB
25. VOC Setpnt Max	The user cannot increase the setpoint to more than this value.	1000 PPB	0 to 1000 PPB	1 PPB
26. VOC setpnt	VOC setpoint.	800 PPB	0 to 1000 PPB (see min and max value)	1 PPB
27. VOC Mode	Enable or disable VOC operation mode.	OFF	ON or OFF	--



Step / Display	Description	Default	Range / Offset	Increment
----------------	-------------	---------	----------------	-----------

Fan Speed and User Control

28. FAN ON SPEED PERCNT	The minimum fan speed when the fan system mode is ON.	20%	0 to 100%	1%
29. FAN MODE	Fan control mode you want to authorize to the user in operation mode.	OFF	OFF, Auto (Automatic), ON	--

Analog Output 1 (AO1)

30. AO1 Min Volt	Select the desired minimum voltage ("zero" value) for the AO1 ramp.	0 V	0 to 10 V	0.1 V
31. AO1 Max Volt	Select the desired maximum voltage ("span" value) for the AO1 ramp.	10 V	0 to 10V	0.1 V
32. AO1 Mode	Determines how the controller calculates the AO1 ramp output value. The controller compares all the enabled input demands (steps 34 to 40) and uses the highest demand or the average of all demands.	HIGH	HIGH (Highest value) or AvrG (Average of all values)	--
33. AO1 DIREV	Direction of the analog signal: Direct (e.g. 0 to 10Vdc) or Reverse (e.g. 10 to 0Vdc).	Dir	Dir (Direct) or rEv (Reverse)	--
34. AO1 Fan	Add fan to AO1 mode (step 32).	OFF	ON or OFF	--
35. AO1 Cool	Add cooling to AO1 mode (step 32).	OFF	ON or OFF	--
36. AO1 Heat	Add heating to AO1 mode (step 32).	OFF	ON or OFF	--
37. AO1 Dehum	Add dehumidification to AO1 mode (step 32).	OFF	ON or OFF	--
38. AO1 Hum	Add humidification to AO1 mode (step 32).	OFF	ON or OFF	--
39. AO1 Co2	Add CO2 to AO1 mode (step 32).	OFF	ON or OFF	--
40. AO1 VOC	Add VOC to AO1 mode (step 32).	OFF	ON or OFF	--

Analog Output 2 (AO2)

41. AO2 Min Volt	Select the desired minimum voltage ("zero" value) for the AO2 ramp.	0 V	0 to 10 V	0.1 V
42. AO2 Max Volt	Select the desired maximum voltage ("span" value) for the AO2 ramp.	10 V	0 to 10V	0.1 V
43. AO2 Mode	Determines how the controller calculates the AO2 ramp output value. The controller compares all the enabled input demands (steps 45 to 51) and uses the highest demand or the average of all demands.	HIGH	HIGH (Highest value) or AvrG (Average of all values)	--
44. AO2 DIREV	Direction of the analog signal: Direct (e.g. 0 to 10Vdc) or Reverse (e.g. 10 to 0Vdc).	Dir	Dir (Direct) or rEv (Reverse)	--
45. AO2 Fan	Add fan to AO2 mode (step 43).	OFF	ON or OFF	--
46. AO2 Cool	Add cooling to AO2 mode (step 43).	OFF	ON or OFF	--
47. AO2 Heat	Add heating to AO2 mode (step 43).	OFF	ON or OFF	--
48. AO2 Dehum	Add dehumidification to AO2 mode (step 43).	OFF	ON or OFF	--
49. AO2 Hum	Add humidification to AO2 mode (step 43).	OFF	ON or OFF	--
50. AO2 Co2	Add CO2 to AO2 mode (step 43).	OFF	ON or OFF	--
51. AO2 VOC	Add VOC to AO2 mode (step 43).	OFF	ON or OFF	--

Binary Output 1 (BO1)



Step / Display	Description	Default	Range / Offset	Increment
52. BO1 Mode	Determines how the controller calculates the BO1 ramp output value. The controller compares all the enabled input demands (steps 59 to 65) and uses the highest demand or the average of all demands.	HIGH	HIGH (Highest value) or AvrG (Average of all values)	--
53. BO1 DIREV	Direction of the binary signal: NO (Normally Open) or NC (Normally Closed).	NO	NO (Normally open) or NC (Normally closed)	--
54. BO1 TPM Hyst	BO1 operates using hysteresis (step 57 and 58) or TPM (step 55).	HYST	HYST (Hysteresis) or TPM (Time proportional modulation)	--
55. BO1 TPM CPH	If BO1 is set to TPM at step 54, select the number of cycles per hour.	4	3, 4 or 8 CPH (Cycles per hour)	--
56. BO1 Anti Cycle Sec	Select the delay before activating or re-activating the contact.	0 sec	0 to 300 sec	1 sec
57. BO1 Hyst Low Percnt	If BO1 is set to HYST at step 54, select the hysteresis low range percentage.	20%	0 to 100%	1%
58. BO1 Hyst High Percnt	If BO1 is set to HYST at step 54, select the hysteresis high range percentage.	80%	0 to 100%	1%
59. BO1 Fan	Add fan to BO1 mode (step 52).	OFF	ON or OFF	--
60. BO1 Cool	Add cooling to BO1 mode (step 52).	OFF	ON or OFF	--
61. BO1 Heat	Add heating to BO1 mode (step 52).	OFF	ON or OFF	--
62. BO1 Dehum	Add dehumidification to BO1 mode (step 52).	OFF	ON or OFF	--
63. BO1 Hum	Add humidification to BO1 mode (step 52).	OFF	ON or OFF	--
64. BO1 Co2	Add CO2 to BO1 mode (step 52).	OFF	ON or OFF	--
65. BO1 VOC	Add VOC to BO1 mode (step 52).	OFF	ON or OFF	--

Binary Output 2 (BO2)

66. BO2 Mode	Determines how the controller calculates the BO2 ramp output value. The controller compares all the enabled input values (steps 73 to 79) and uses the highest demand or the average of all demands.	HIGH	HIGH (Highest value) or AvrG (Average of all values)	--
67. BO2 DIREV	Direction of the binary signal: NO (Normally Open) or NC (Normally Closed).	NO	NO (Normally open) or NC (Normally closed)	--
68. BO2 TPM Hyst	BO2 operates using hysteresis (step 71 and 72) or TPM (step 69).	HYST	HYST (Hysteresis) or TPM (Time proportional modulation)	--
69. BO2 TPM CPH	If BO2 is set to TPM at step 68, select the number of cycles per hour.	4	3, 4 or 8 CPH (Cycles per hour)	--
70. BO2 Anti Cycle Sec	Select the delay before activating or re-activating the contact.	0 sec	0 to 300 sec	1 sec
71. BO2 Hyst Low Percnt	If BO2 is set to HYST at step 68, select the hysteresis low range percentage.	20%	0 to 100%	1%
72. BO2 Hyst High Percnt	If BO2 is set to HYST at step 68, select the hysteresis high range percentage.	80%	0 to 100%	1%
73. BO2 Fan	Add fan to BO2 mode (step 66).	OFF	ON or OFF	--
74. BO2 Cool	Add cooling to BO2 mode (step 66).	OFF	ON or OFF	--
75. BO2 Heat	Add heating to BO2 mode (step 66).	OFF	ON or OFF	--
76. BO2 Dehum	Add dehumidification to BO2 mode (step 66).	OFF	ON or OFF	--
77. BO2 Hum	Add humidification to BO2 mode (step 66).	OFF	ON or OFF	--
78. BO2 Co2	Add CO2 to BO2 mode (step 66).	OFF	ON or OFF	--
79. BO2 VOC	Add VOC to BO2 mode (step 66).	OFF	ON or OFF	--



Step / Display	Description	Default	Range / Offset	Increment
Analog and Binary Inputs (AI1 and BI1)				
80. AI1 Mode	Select the type of sensor and event associated with input AI1.	OFF	OFF (None), OAT (Outside Air Temperature), OCC (Occupancy status), nSb (Night set back status), dFt (Dirty filter), FLS (Air Flow Switch), FLP (Air Flow Protection/Lockout)	--
81. BI1 Mode	Select the type of sensor and event associated with input BI1.	OFF	OFF (None), OCC (Occupancy status), nSb (Night set back status), dFt (Dirty filter), FLS (Air Flow switch), FLP (Air Flow Protection/Lockout)	--
82. Extern Temp Offset	The display shows the temperature read by input AI1. Adjust the offset by comparing it with a known value.	Current value	-40°F to 257°F / offset: ±18°F (-40°C to 125°C / offset: ±10°C)	0.2°F (0.1°C)

Outside Air Temperature (OAT)

The following features apply only if OAT is selected for AI1 at step 80.

83. AO1 OAT Hi Temp	AO1 no longer modulates and remains at its minimum voltage if the OAT read at AI1 is higher than this value.	122°F (50°C)	-40°F to 257°F (-40°C to 125°C)	0.2°F (0.1°C)
84. AO1 OAT Low Temp	AO1 no longer modulates and remains at its minimum voltage if the OAT read at AI1 is lower than this value.	-40°F (-40°C)	-40°F to 257°F (-40°C to 125°C)	0.2°F (0.1°C)
85. AO2 OAT Hi Temp	Same as step 83, except it applies to AO2.	122°F (50°C)	-40°F to 257°F (-40°C to 125°C)	0.2°F (0.1°C)
86. AO2 OAT Low Temp	Same as step 84, except it applies to AO2.	-40°F (-40°C)	-40°F to 257°F (-40°C to 125°C)	0.2°F (0.1°C)
87. BO1 OAT Hi Temp	BO1 remains in its inactive or "normal" state if the OAT read at AI1 is higher than this value.	122°F (50°C)	-40°F to 257°F (-40°C to 125°C)	0.2°F (0.1°C)
88. BO1 OAT Low Temp	BO1 remains in its inactive or "normal" state if the OAT read at AI1 is lower than this value.	-40°F (-40°C)	-40°F to 257°F (-40°C to 125°C)	0.2°F (0.1°C)
89. BO2 OAT Hi Temp	Same as step 87, except it applies to BO2.	122°F (50°C)	-40°F to 257°F (-40°C to 125°C)	0.2°F (0.1°C)
90. BO2 OAT Low Temp	Same as step 88, except it applies to BO2.	-40°F (-40°C)	-40°F to 257°F (-40°C to 125°C)	0.2°F (0.1°C)

Occupied/Unoccupied Mode (OCC)

The following features apply only if OCC or NSB is selected for AI1 or BI1 at steps 80 or 81.

91. Unocc Cool Setpnt Min	The user cannot decrease the unoccupied cooling setpoint to less than this value.	50°F (10°C)	32°F to 257°F (0°C to 125°C)	0.2°F (0.1°C)
92. Unocc Cool Setpnt Max	The user cannot increase the unoccupied cooling setpoint to more than this value.	104°F (40°C)	32°F to 257°F (0°C to 125°C)	0.2°F (0.1°C)
93. Unocc Cool Setpnt	Unoccupied cooling setpoint.	89.6°F (32°C)	32°F to 257°F (see min and max value) (0°C to 125°C)	0.2°F (0.1°C)
94. Unocc Heat Setpnt Min	The user cannot decrease the unoccupied heating setpoint to less than this value.	50°F (10°C)	32°F to 257°F (0°C to 125°C)	0.2°F (0.1°C)
95. Unocc Heat Setpnt Max	The user cannot increase the unoccupied heating setpoint to more than this value.	104°F (40°C)	32°F to 257°F (0°C to 125°C)	0.2°F (0.1°C)
96. Unocc Heat Setpnt	Unoccupied heating setpoint.	64.4°F (18.0°C)	32°F to 257°F (see min and max value) (0°C to 125°C)	0.2°F (0.1°C)

Proportional Band and Integral Time

97. Cool P band	Cooling ramp proportional band.	9°F 5°C	3.6°F to 90°F 2°C to 50°C	0.2°F (0.1°C)
98. Heat P band	Heating ramp proportional band.	9°F 5°C	3.6°F to 90°F 2°C to 50°C	0.2°F (0.1°C)

Step / Display	Description	Default	Range / Offset	Increment
99. Humdty P band	Humidity ramp proportional band.	5 %RH	2.0 % to 50.0 %RH	0.1 %RH
100. CO2 P band	CO2 ramp proportional band.	500 PPM	10 to 2000 PPM	1 PPM
101. VOC P Pand	VOC ramp proportional band.	500 PPB	10 to 1000 PPB	1 PPB
102. Cool I Time Sec	Cooling integral factor compensation.	60 sec	1 to 120 sec	1 sec
103. Heat I Time Sec	Heating integral factor compensation.	60 sec	1 to 120 sec	1 sec
104. Humdty I Time Sec	Humidity integral factor compensation.	60 sec	1 to 120 sec	1 sec
105. CO2 I Time Sec	CO2 integral factor compensation.	60 sec	1 to 120 sec	1 sec
106. VOC I Time Sec	VOC integral factor compensation.	60 sec	1 to 120 sec	1 sec
107. Temp Deadband	Temperature deadband value. The minimum range between the cooling and heating setpoint within which the controller will not take action for the temperature reading.	3.6°F (2°C)	0°F to 36°F (0°C to 20°C)	0.2°F (0.1°C)
108. Humidity Deadband	Humidity deadband value. The minimum range between the dehumidification and humidification setpoint within which the controller will not take action for the humidity reading.	2 %RH	0% to 20% RH	0.1% RH

Network Settings (BACnet / Modbus)

109. Select Netwrk Proto	Select the desired network protocol.	bAC	bAC (BACnet MS/TP) or mod (Modbus)	--
110. BACnet Baud Rate	Set the desired MS/TP baud rate setting.	Auto	Auto (Automatic detection), 9.6k, 19.2k, 38.4k, 57.6K, and 76.8k	--
111. MSTP MAC Addrss	Select the desired MSTP MAC Address.	0	1 to 254	1
112. MSTP Max Master	Select the desired MSTP MAX address for the master device.	127	1 to 127	1
113. Adjust Device Inst	Select Yes to change manually and continue to the next step. If you select No, the device instance will be modified automatically according to the MAC address.	No	No or Yes	--
114. 015325	If Yes was selected at step 113, use the arrow keys to change the value and press the [*] button to move to the next digit.	Current value	0 to 4194302	1
115. Modbus Baud rate	Set the desired Modbus baud rate setting.	Auto	Auto (Automatic detection), 9.6k, 19.2k, 38.4k, 57.6K	--
116. Modbus Port Config	Select the desired parity and number of stop bits for Modbus communication.	NP2S	NP2S (No parity, 2 Stop bits) EP1S (Even parity, 1 stop bit) OP1S (Odd parity, 1 stop bit)	--
117. Modbus Addrss	Select the desired Modbus address.	1	1 to 246	1

General Settings

118. Local Unit	Select the unit measure displayed on the controller.	MET°C	MET°C (Metric) or ImP°F (Imperial)	--
119. Show Temp	Select No to hide Temperature reading in operation mode.	Yes	No or Yes	--
120. Show Humdty	Select No to hide Humidity reading in operation mode.	Yes	No or Yes	--
121. Show CO2	Select No to hide CO2 reading in operation mode.	Yes	No or Yes	--
122. Show VOC	Select No to hide VOC reading in operation mode.	Yes	No or Yes	--
123. Auto Scroll	In operation mode, the sensor values can scroll automatically (ON) or manually by pressing the enter key.	ON	ON or OFF	--

Operation Menus

This menu is accessible through normal operation mode. The Mode Selector jumper (JP3) of the thermostat must be set to the "RUN" position (Operation Mode). Refer to Wiring on page 3.

1. Press the [*] and [↵] buttons simultaneously for 5 seconds. The "Enter Password" screen appears.
2. Enter the password within 1 minute by using the arrow keys to increase or decrease the value and the [*] and [↵] buttons to toggle between the digits.
 - a. Password **372** = Temperature Offset Menu
 - b. Password **637** = Network Settings Menu
3. If you enter the wrong password, the thermostat displays "Error" and returns to Operation Mode. The thermostat will return to normal mode if you navigate through the entire menu and do not make any selection, or if you do not press any key for 5 minutes. The changed values will be saved automatically.

Step / Display	Description	Default	Range / Offset	Increment
----------------	-------------	---------	----------------	-----------

Menu 372 – Temperature Offset

1. Intrn Temp Offset	The display shows the temperature read by the temperature sensor. Adjust the offset by comparing it with a known value.	Current value	32°F to 122°F / offset: ±9°F (0°C to 50°C / offset: ±5°C)	0.2°F (0.1°C)
2. Extern Temp Offset	The display shows the temperature read by input AI1. Adjust the offset by comparing it with a known value.	Current value	-40°F to 257°F / offset: ±18°F (-40°C to 125°C / offset: ±10°C)	0.2°F (0.1°C)
3. Humdty Offset	The display shows the relative humidity read by the humidity sensor. Adjust the offset by comparing it with a known value.	Current value	0% to 100% RH / Offset: ±5%	0.1% RH
4. CO2 Offset	The display shows the CO2 level read by the CO2 sensor. Adjust the offset by comparing it with a known value.	Current value	0 to 2000 PPM / Offset: ± 200 PPM	1 PPM
5. VOC Offset	The display shows the VOC level read by the VOC sensor. Adjust the offset by comparing it with a known value.	Current value	0 to 1000 PPB / Offset: ± 100 PPB	1 PPB

Menu 637 – Network Settings

6. Select Netwrk Proto	Select the desired network protocol.	bAC	bAC (BACnet MS/TP) or mod (Modbus)	--
7. BACnet Baud Rate	Set the desired MS/TP baud rate setting.	Auto	Auto (Automatic detection), 9.6k, 19.2k, 38.4k, 57.6K, and 76.8k	--
8. MSTP MAC Addrss	Select the desired MSTP MAC Address.	0	1 to 254	1
9. MSTP Max Master	Select the desired MSTP MAX address for the master device.	127	1 to 127	1
10. Adjust Device Inst	Select Yes to change manually and continue to the next step. If you select No, the device instance will be modified automatically according to the MAC address.	No	No or Yes	--
11. 015325	If Yes was selected at step 8, use the arrow keys to change the value and press the [*] button to move to the next digit.	Current value	0 to 4194302	1
12. Modbus Baud rate	Set the desired Modbus baud rate setting.	Auto	Auto (Automatic detection), 9.6k, 19.2k, 38.4k, 57.6K	--
13. Modbus Port Config	Select the desired parity and number of stop bits for Modbus communication.	NP2S	NP2S (No parity, 2 Stop bits) EP1S (Even parity, 1 stop bit) OP1S (Odd parity, 1 stop bit)	--
14. Modbus Addrss	Select the desired Modbus address.	1	1 to 246	1



Reset to Factory Default Settings



This will erase all actual configurations and replace them with the factory default settings.

1. The Mode Selector jumper (JP3) of the thermostat must be set to the "RUN" position (Operation Mode). Refer to Wiring on page 3.
2. During the power up sequence of the controller (when the firmware version is displayed), press and hold both the and buttons.
3. The "Enter Password" screen appears. Enter **372** within 1 minute by using the arrow keys to increase or decrease the value and the and buttons to toggle between the digits.
4. Use the arrow buttons to select YES and then press .

Operation Mode



Set the Mode Selector Jumper **JP3** to the "RUN" mode (Operation Mode).
For more information, see

Wiring on page 3.

Press to change setpoint

Press to change setpoint

Press to change setpoint

Press to change setpoint

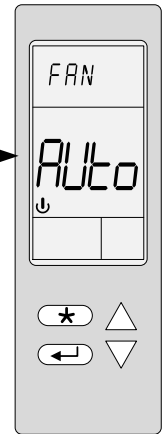
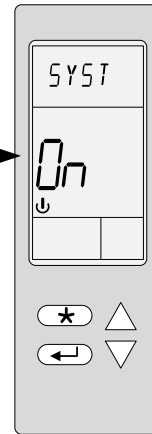
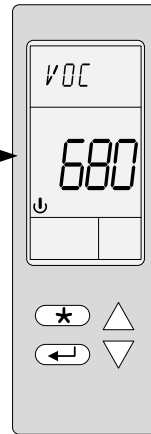
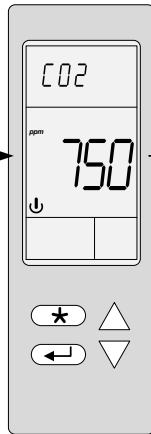
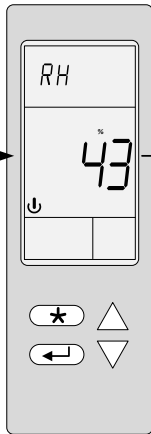
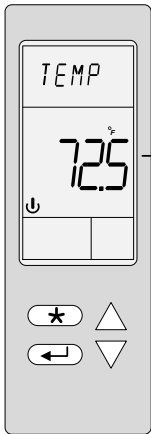

Press to change temp mode:
Auto
Heat
Cool
Off

Press to change RH mode:
Auto
HUM
DEHUM
OFF

Press to change CO2 mode:
ON
OFF

Press to change VOC mode:
ON
OFF

Press to change system mode:
ON
OFF

Press to change fan mode:
Auto
ON
OFF





Power Up

Upon power up, the LCD illuminates, and all segments appear for 2 seconds. The controller then displays its current version for 2 seconds.



LCD Backlight

Pressing any key illuminates the LCD for 4 seconds.

Night Set Back (NSB) Mode

This function is available only if the nSb (Night Set Back contact) option is selected at Step 80, "A11 Mode" or Step 81, "B11 Mode". If the contact is triggered, the controller enters NSB mode (the  symbol appears) and uses the NSB setpoints defined at Steps 93, "Unocc Cool Setpnt" and 96, "Unocc Heat Setpnt". When the contact is not triggered, the  icon appears indicating the normal operation.

No Occupancy Mode

This function is available only if the OCC (Occupancy contact) option is selected at Step 80, "A11 Mode" or Step 81, "B11 Mode". If the contact is triggered, the  icon appears indicating normal "Occupied" operation. When the contact is not triggered, the controller enters into the Unoccupied mode (the  symbol appears) and uses the unoccupied setpoints defined at Steps 93, "Unocc Cool Setpnt" and 96, "Unocc Heat Setpnt" respectively.



Appendix - Application Profiles

This appendix provides additional information about the application profiles (App Profiles) used in the ARO Series Universal Room Controllers.

APP PROFILE 1

Outside Air Application (Temperature only)

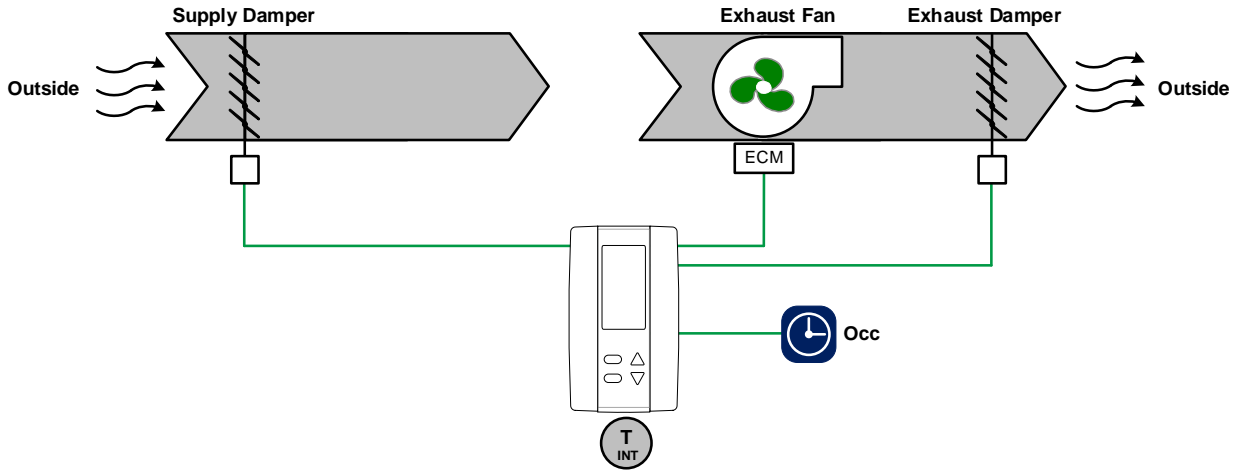

When selecting the option "1" from the application profiles menu, the controller automatically configures the following options:

AO1	Fan	AO2	BO1	Fan	BO2	AI	BI1	Occupancy	System Modes
Demand Source	Fan	OFF	Demand Source	Fan	OFF	OFF	Configuration	Occupancy	Main System
Control Mode	Highest		Control Mode	Highest					Temperature
Direction	Direct		Direction	Direct					Humidity
Min. Value	0%		TPM/Hysteresis	Hysteresis					CO2
Max. Value	100%		Hysteresis Low	0%					VOC
			Hysteresis High	20%					Off

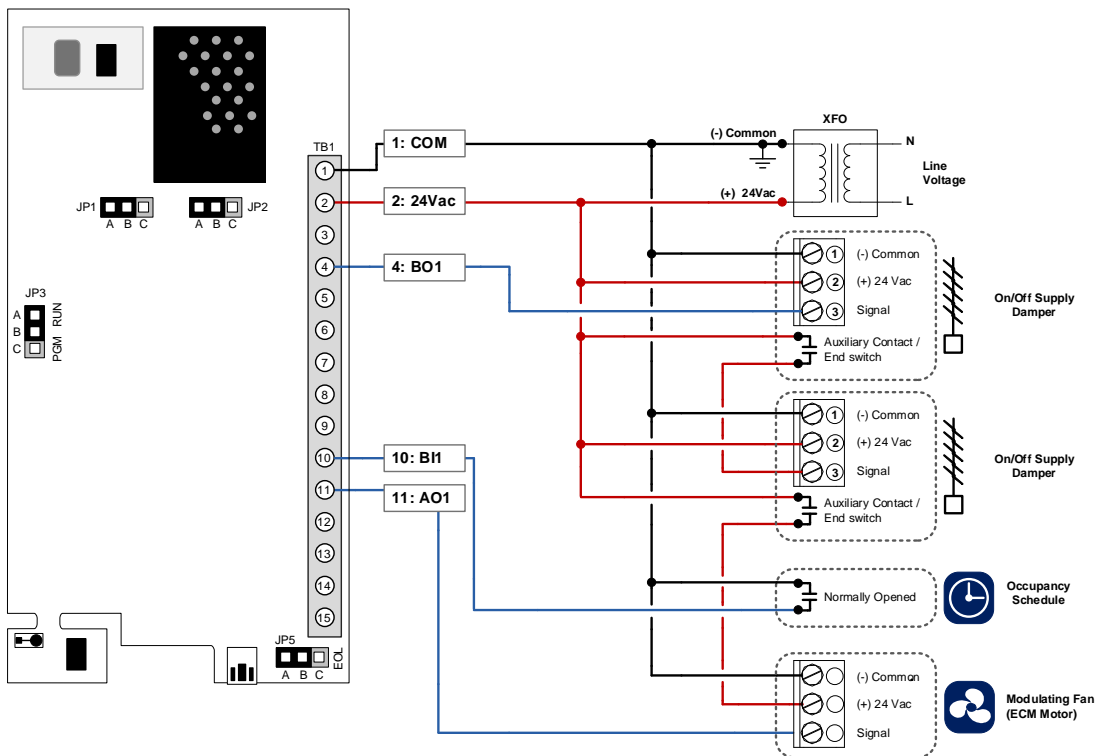



APP PROFILE 2:

Conference Room (Temp, RH, and CO₂)

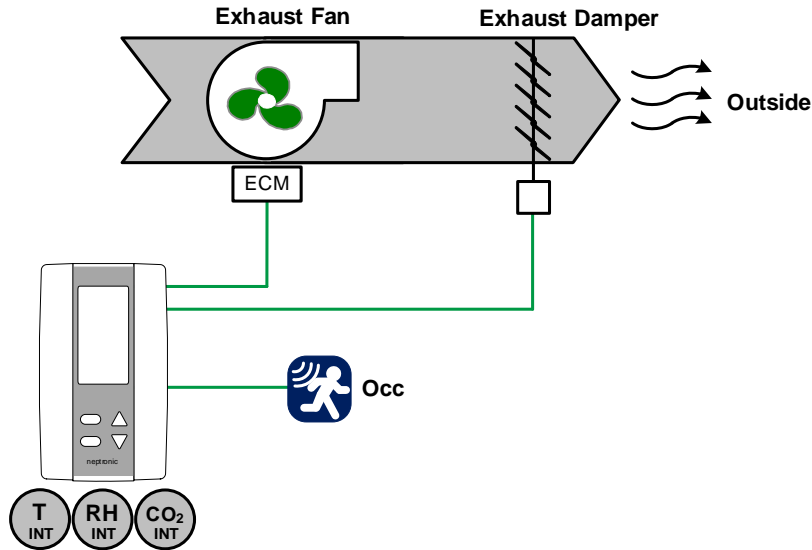

When selecting the option "2" from the application profiles menu, the controller automatically configures the following options:

AO1 Demand Source Fan Control Mode Average Direction Direct Min. Value 0% Max. Value 100%	AO2 OFF	BO1 Demand Source Fan Control Mode Average Direction Direct TPM/Hysteresis Hysteresis Hysteresis Low 0% Hysteresis High 20%	BO2 OFF	AI OFF	B11 Configuration Occupancy	System Modes Main System On Temperature Auto Humidity Auto CO2 On VOC Off
--	----------------	---	----------------	---------------	--------------------------------	--

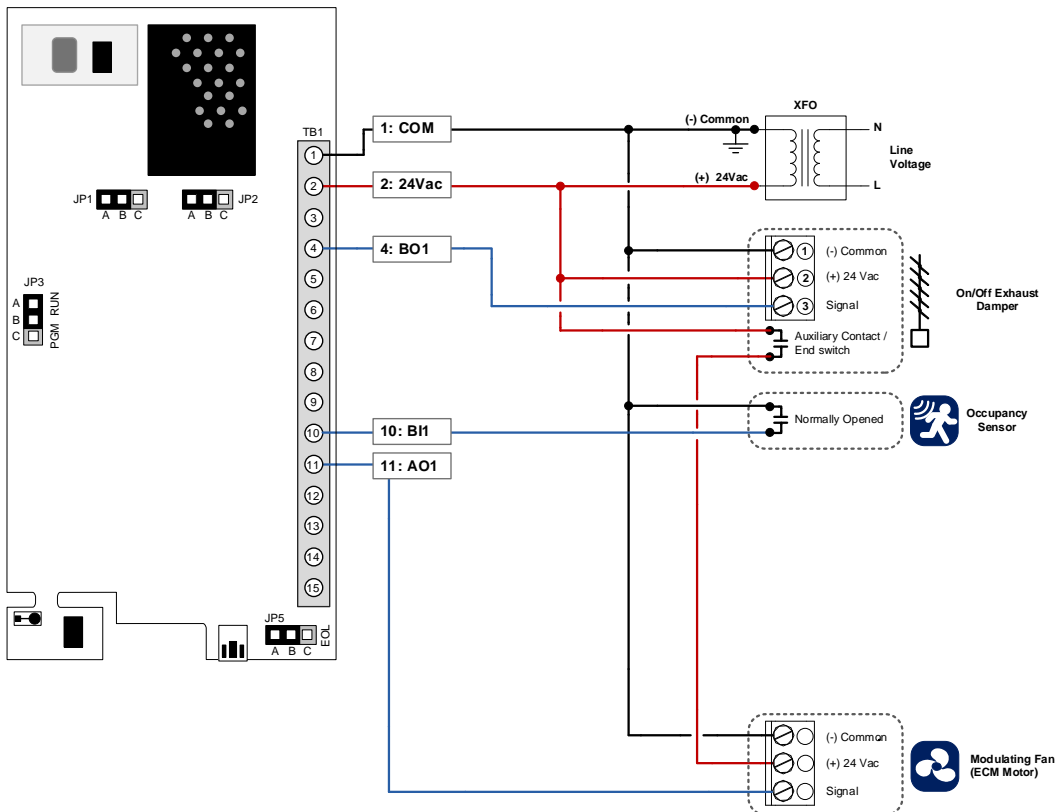



Recycling at end of life: please return this product to your Neptronic local distributor for recycling. If you need to find the nearest Neptronic authorized distributor, please consult www.neptronic.com.



neptronic[®]

400 Lebeau blvd, Montreal, Qc, H4N 1R6, Canada

www.neptronic.com

Toll free in North America: 1-800-361-2308

Tel.: (514) 333-1433

Fax: (514) 333-3163

Customer service fax: (514) 333-1091

Monday to Friday: 8:00am to 5:00pm (Eastern time)