

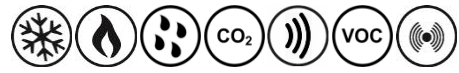

Models

Model #	Temp	RH	CO ₂	PIR	VOC	Color
TDU00-100 TDF00-100	•					grey LCD, white enclosure
TDU00-101 TDF00-101	•	•				
TDU00-102 TDF00-102	•	•	•			
TDU00-103 TDF00-103	•		•			
TDU00-104 TDF00-104	•			•		
TDU00-105 TDF00-105	•	•		•		
TDU00-106 TDF00-106	•	•	•		•	
TDU00-107 TDF00-107	•	•	•	•	•	
TDU00-108 TDF00-108	•	•	•	•		



TDU00 Series



TDF00 Series

Model #	Temp	RH	CO ₂	PIR	VOC	Color
TDU30-100 TDF30-100	•					black LCD, black enclosure
TDU30-101 TDF30-101	•	•				
TDU30-102 TDF30-102	•	•	•			
TDF30-103	•		•			
TDU30-104 TDF30-104	•			•		
TDU30-105 TDF30-105	•	•		•		
TDU30-106 TDF30-106	•	•	•		•	
TDU30-107 TDF30-107	•	•	•	•	•	
TDU30-108 TDF30-108	•	•	•	•		



TDU30 Series



TDF30 Series

Model #	Temp	RH	CO ₂	PIR	VOC	Color
TDU60-100 TDF60-100	•					black LCD, white enclosure
TDU60-101 TDF60-101	•	•				
TDU60-102 TDF60-102	•	•	•			
TDF60-103	•		•			
TDU60-104 TDF60-104	•			•		
TDU60-105 TDF60-105	•	•		•		
TDU60-106 TDF60-106	•	•	•		•	
TDU60-107 TDF60-107	•	•	•	•	•	
TDU60-108 TDF60-108	•	•	•	•		



TDU60 Series



TDF60 Series

Features

Onboard Sensors

- Temperature sensor (°C/°F)
- Humidity sensor (%RH), select models
- Carbon dioxide sensor (CO₂), select models
- PIR motion detection sensor, select models
- Volatile organic compounds (VOC), select models

Functions

- TDU series used to configure and operate the EVCB VAV controllers
- TDF series used to configure and operate the EFCB Fan Coil controllers
- Three wire connection between room sensor and controller
- Elegant design
- Universal wall-mount design
- Selectable Fahrenheit or Celsius scale
- Network service port via on-board mini USB connector
- Dimensions: 124mm x 83mm x 20mm (4.88" x 3.25" x 0.78")
- Dimensions for models with CO₂ sensor:
124mm x 83mm x 24mm (4.88" x 3.25" x 0.95")

Technical Specifications

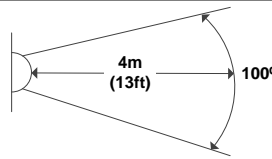
Description	TDU00 / TDU30 / TDU60 / TDF00 / TDF30 / TDF60 Series
Temperature Sensor	
<i>Setpoint Range</i>	10°C to 40°C [50°F to 104°F]
<i>Control Accuracy</i>	Temperature: ±0.4°C [0.8°F]
<i>Display Resolution</i>	±0.1°C [0.2°F]
Humidity Sensor (select models)	
<i>Setpoint Range (EFCB only)</i>	10 to 65%RH
<i>Control Accuracy (EFCB only)</i>	±3.5% RH
<i>Display Resolution</i>	0.1%
CO₂ Sensor (select models)	
<i>Operating Principle</i>	Self-calibrating, Non-Dispersive Infrared (NDIR)
<i>Sensor Range</i>	400 to 2000 ppm
<i>Accuracy</i>	±30 ppm ±3% of reading (Accuracy is defined after minimum 3 weeks of continuous operation)
<i>Response Time</i>	2 minutes by 90%
PIR Motion Sensor (select models)	
<i>Operating Principle</i>	Passive Infrared (PIR)
<i>Detection Angle</i>	100°
<i>Detection Distance</i>	4m [13ft]
<i>Detection Area</i>	
VOC Sensor (select models)	
<i>Operating Principle</i>	Self-calibrating, Non-Dispersive Infrared (NDIR)
<i>Sensor Range</i>	0-1000 ppb isobutylene equivalent tVOCs
<i>Response Time</i>	< 5 seconds for tVOC
<i>Start up Time</i>	15 minutes
Other	
<i>Electrical connection</i>	Three wires to EVCB/EFCB controller and two wires to BACnet/Modbus network 0.8 mm ² [18 AWG] minimum
<i>Network service port</i>	Mini USB connector
<i>Power supply</i>	24Vac
<i>Power consumption</i>	1VA
<i>Operating temperature</i>	0°C to 50°C [32°F to 122°F]
<i>Storage temperature</i>	-30°C to 50°C [-22°F to 122°F]
<i>Relative Humidity</i>	5 to 95 % non-condensing
<i>Degree of protection of housing</i>	IP 30 (EN 60529)
<i>Weight</i>	135 g. [0.30 lb]

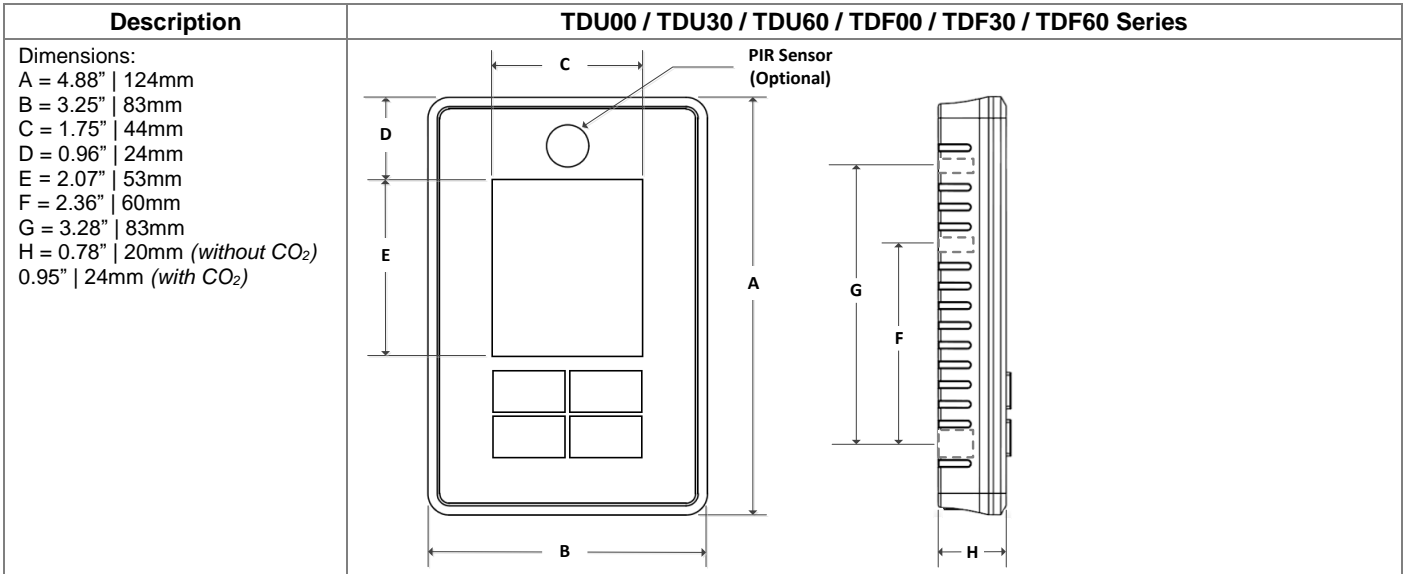

Interface

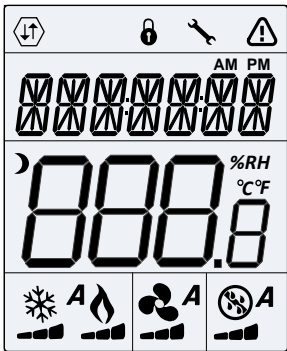

	Network Communication		User Lock		Programming Mode (Technician Setting)
	Alarm Status		Energy Saving Mode (NSB/OCC)	AM PM	Time
°C °F %RH	°C: Celsius Scale °F: Fahrenheit Scale %RH: Humidity	A	Automatic Mode		Cooling
	Heating		Fan		Humidify/De-humidify (EFCB only)

Wiring

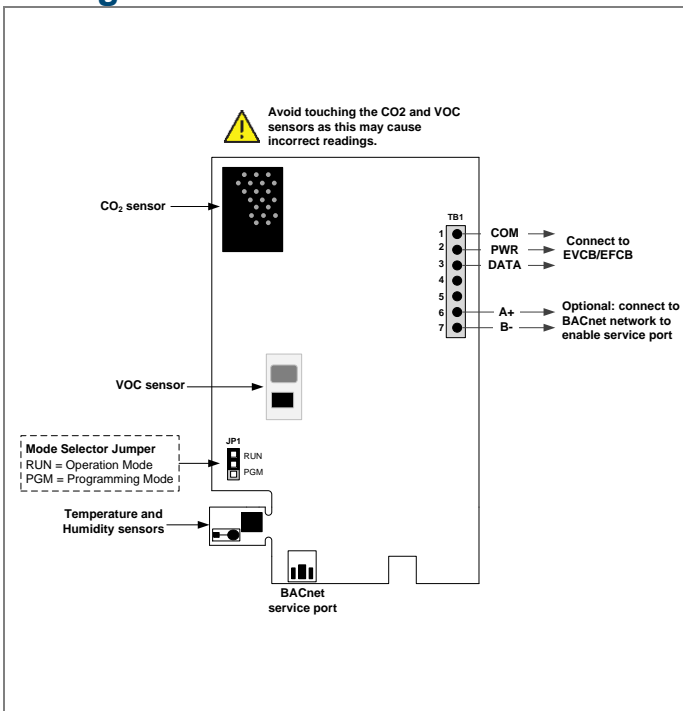

We strongly recommend that all Neptronic products be wired to a separate grounded transformer and that transformer shall service only Neptronic products. This precaution will prevent interference with, and/or possible damage to incompatible equipment.

Mode Selection (JP1)

	<p>RUN: Digital Room Sensor is in Operation Mode. Digital Room Sensor must be set in this mode to operate properly. If not locked, following setpoint and control mode options can be modified by the end user:</p> <ul style="list-style-type: none"> • Heating and Cooling ON • Cooling only ON • Heating only ON • OFF <p>(EFCB only)</p> <ul style="list-style-type: none"> • Fan ON • Humidify and De-humidify ON • Humidify only ON • Dehumidify only ON
	<p>PGM: Digital Room Sensor is set in Programming Mode.</p>



Mounting Instructions

 **CAUTION: Remove power to avoid a risk of malfunction.**



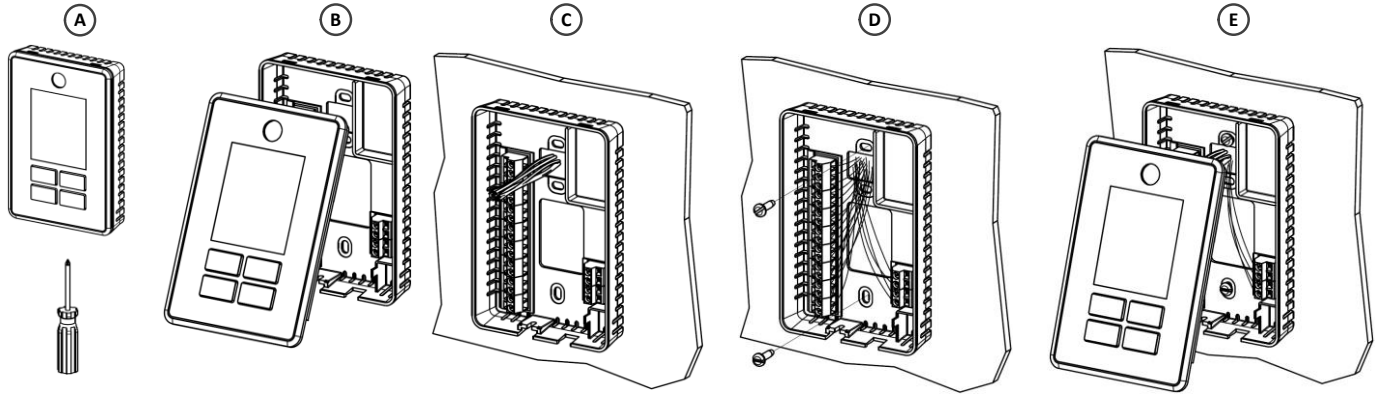

- A. Remove the captive screw that's holding the base and the front cover of the unit together.
- B. Lift the front cover of the unit to separate it from the base.
- C. Pull all wires through the holes in the base.
- D. Secure the base to the wall using wall anchors and screws (supplied). Make the appropriate connections.
- E. Mount the control module on the base and secure using the screw.



Access to Menus

The menus and options are the same for both the TDU and TDF Digital Room Sensors. However, the action button or the button used to access the menus and save changes is different for each Digital Room Sensor.

Action Buttons on Digital Room Sensor

Action Button	
TDU	TDF
	
	



Operation Mode

The Mode Selector Jumper JP1 must be set to the RUN position (Operation Mode). Refer to the Wiring section on page 3.

EVCB

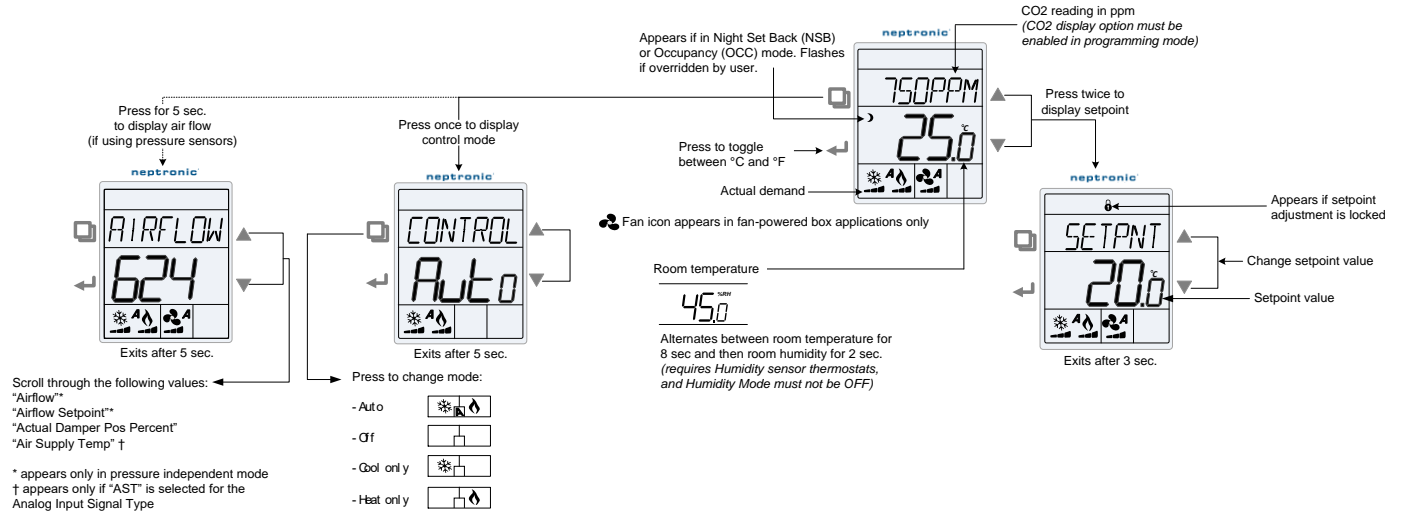

EFCB

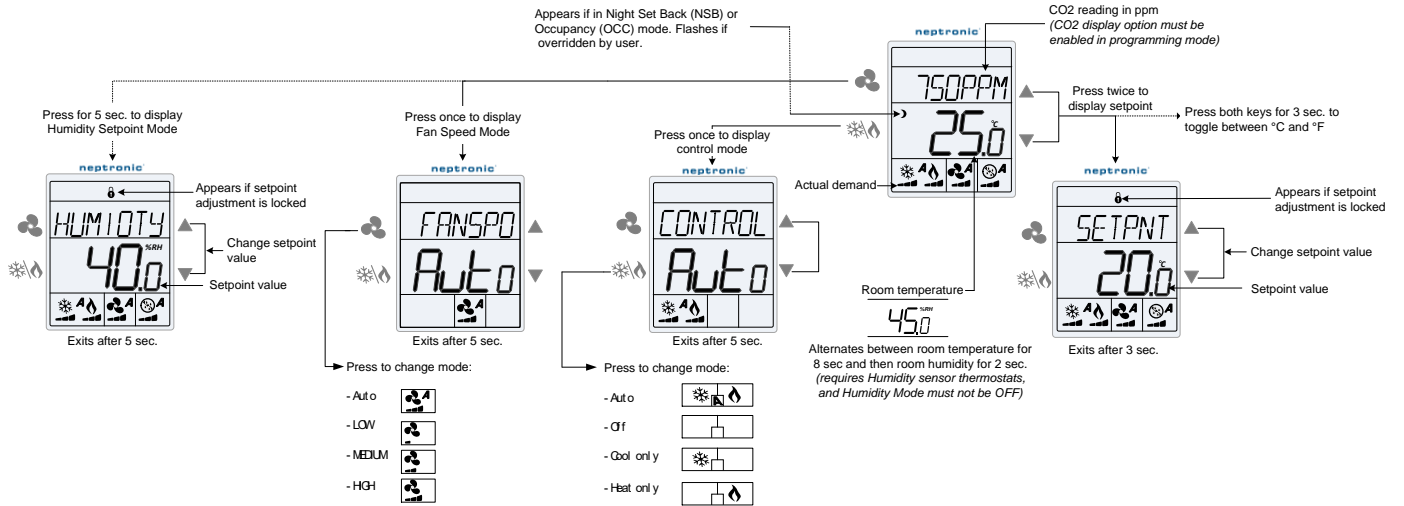



Power Up

Upon power up, the LCD illuminates and all segments appear for 2 seconds. The Digital Room Sensor then displays its current version for 2 seconds followed by the current version of the controller for 2 seconds. Pressing any key on the Digital Room Sensor illuminates the LCD for 4 seconds.

Temperature Display and Setpoint

The Digital Room Sensor displays the temperature reading. If the sensor is disconnected or short circuited, the unit displays the sensor's limits. To toggle the temperature scale between °C and °F, press the key on the TDU or both the and keys for 3 seconds on the TDF.

To display the setpoint, press the or key twice. The setpoint appears for 5 seconds. To adjust the setpoint, press the arrow keys while the temperature is displayed. If the setpoint adjustment has been locked, the lock symbol appears.

CO₂ (Digital Room Sensor with CO₂ Option)

If enabled via the configuration menu, the Digital Room Sensor displays the CO₂ reading on the first line above the temperature reading. If CO₂ display is enabled, the time will not be displayed.

Humidity Setpoint Display and Adjustment (Digital Room Sensor with Humidity Option)

If enabled via the configuration menu for the EVCB and in a humidity mode other than OFF for the EFCB, the Digital Room Sensor displays the temperature reading for 8 seconds and then displays the humidity reading for 2 seconds. If the sensor is disconnected or short circuited, then the unit displays the sensor's limit.

To access the humidity setpoint (EFCB only), press the key for 5 seconds. The humidity setpoint will be displayed for 5 seconds. To adjust the setpoint press the and keys while the setpoint is displayed. The unit will return to normal mode if you do not press any key for 3 seconds. The changed values will be saved automatically.

Control Mode

To access the Control Mode, press the key on the TDU or on the TDF. The Control Mode appears for 5 seconds. Press the (TDU) or (TDF) key to scroll through the following control modes. These options can vary depending on the options configured by the installer.

- Auto (Automatic Cooling or Heating)
- Cooling only (on, with cooling symbol)
- Heating only (on, with heating symbol)
- OFF (if it is not disabled in Programming Mode)

Fan Speed Selection Mode (EFCB Only)

To access the Fan Speed selection mode, press the key. The mode appears for 5 seconds. These options can vary depending on the fan speed signal and auto mode settings. If in No Occupancy mode, the button now serves as the override button.

- Automatic speed. Available only if enabled by the installer.
- Low speed
- Medium speed
- High speed

Night Set Back (NSB)

This function is only available if enabled by your installer. If the appropriate digital input contact is triggered, the Digital Room Sensor enters NSB Mode (the symbol appears) and uses the NSB setpoints defined in program mode. Press any key to override NSB for the delay defined in program mode (default: 120 minutes). The symbol flashes to indicate that the NSB mode is overridden (during this time the standard setpoints are used). If the NSB Mode was set to OFF, all outputs will be off for the duration of the period and cannot be overridden.

Occupancy Mode

This function is only available if enabled by your installer. If the appropriate digital input contact is triggered, the Digital Room Sensor enters Occupancy Mode (the symbol appears) and uses the NoOcc setpoints defined in program mode. If not locked, no occupancy mode can be overridden for a period by pressing the () button. Each time you press the () button, 15 minutes are added to the override (up to a maximum defined in program mode). Press the fan () button until "0" is displayed to disable the override. The icon will flash and the remaining override time will be displayed in minutes.



Set Time and Date

1. Press and hold the button for 5 seconds.
2. Use the arrow keys to set the desired value. Press the () button to save and go to the next step. Press the button to go to the previous step without saving.

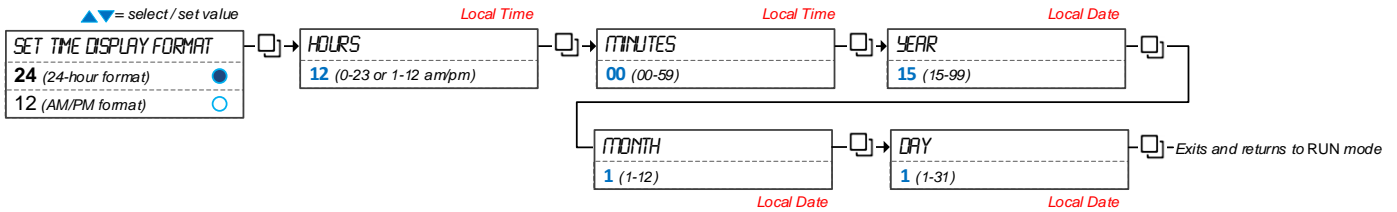

Note: Time will only be displayed on the TDU/TDF when the Bacnet scheduler is active. In order to achieve this, set the proper BACnet Object present value to Yes (1): **EFCB BV.91 – Cfg_ActiveSchedule** or **EVCB BV.70 – Cfg_ActiveSchedule**.

Airflow and Air Supply Temperature

Press and hold the () button for 5 seconds and use the arrow keys to view the “airflow”, “airflow Setpnt”, “actual damper pos percent” and “air Supply Temp”. After 5 seconds without any action, the Digital Room Sensor returns to operation mode. The air supply temperature appears only if analog input AI1 or AI2 are configured with the AST option.

Backlight and Contrast Level Adjustment

For models with the grey LCD screen, the backlight level can be adjusted. For models with the black LCD screen, the contrast level can be adjusted. Press and hold the () and buttons for 5 seconds and enter the password **367** to gain access to the backlight and contrast level adjustment settings. Use the and keys to adjust the backlight or contrast level in three modes: User (digital room sensor is in operation), Occupancy (digital room sensor is idle and occupancy state is active) and No Occupancy (digital room sensor is idle and occupancy state is inactive). Press the () key to save any changes.



Recycling at end of life: please return this product to your Nepronic local distributor for recycling. If you need to find the nearest Nepronic authorized distributor, please consult www.nepronic.com.



nepronic[®]

400 Lebeau blvd, Montreal, Qc, H4N 1R6, Canada

www.nepronic.com

Toll free in North America: 1-800-361-2308

Tel.: (514) 333-1433

Fax: (514) 333-3163

Customer service fax: (514) 333-1091

Monday to Friday: 8:00am to 5:00pm (Eastern time)