

SKR series Steam Humidifier – Kit N

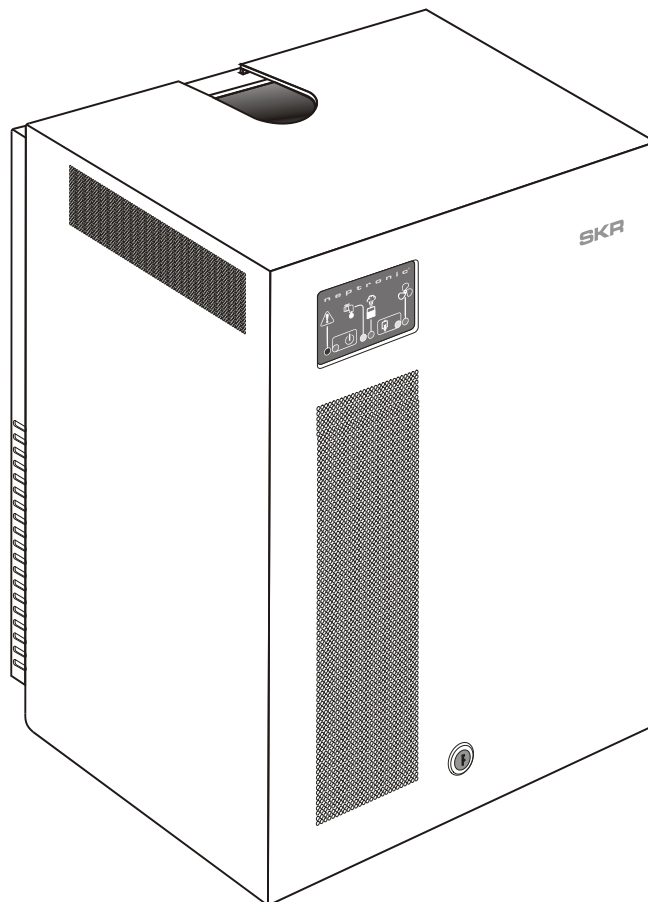

Installation instructions & user manual

READ AND SAVE THESE INSTRUCTIONS

Foreword

Neptronic Company Overview

Founded in 1976, we're a private corporation that designs, manufactures and distributes products for the HVAC industry. Our product line includes intelligent controllers, electronic actuators, actuated valves, humidifiers and electric heaters.

Our products are designed and manufactured by over 250 dedicated employees in our 7,500 m² (80,000 ft²) state-of-the-art facility located in Montreal, Canada. Using a vertical integration model, our entire manufacturing chain is under one roof from software and hardware development, to SMT circuit board assembly, to sheet metal fabrication, to product testing ensuring that our products are engineered to last.

We currently hold several national and international patents and with our continued commitment to research and development, we provide innovative products and technologies for the ever-evolving challenges of the HVAC industry. Exporting over 70% of our sales, we have an exclusive distribution network around the globe that provides comprehensive solutions to our worldwide customers.

About the Manual

These installation and operation instructions have been developed to facilitate the installation of the Steam Humidifier.

- The strict application of these instructions will ensure the conformity of your installation and operation as per the manufacturer's recommendations.
- The application of these instructions is one of the conditions for the application of the warranty.
- The application of these instructions does not ensure, at any time conformity to procedures, regulation or local codes, regarding electric installation and connection to local water supply.

This product has been declared to conform to the applicable Canadian and American safety standards and directives and bear the CSA (c) & (us) mark. The Certificate of Conformity, CSA is available, upon request with the manufacturer.

This product has been declared to conform to applicable European safety and electromagnetic compatibility standards and directives and bear the CE mark. The certificate of conformity CE is available upon request to the manufacturer.

2026[®]: All rights reserved. This document cannot be reproduced totally or partially by any means whether, electronic, mechanical, photocopy, recording or other, without prior written authorization of Neptronic.

Electricity



All work concerned with electrical installation **MUST** only be performed by skilled and qualified technical personnel such as an electrician or a technician with appropriate training). The customer is always responsible for ensuring the suitability of the technical personnel.

Please observe the local regulations concerning the provision of electrical installations.

Correct Use

Neptronic systems and its products are designed only for humidification use. Any other application is not considered appropriate for the intended purpose. The manufacturer cannot be made liable for any damage resulting from incorrect use.

General Warranty

This product is subject to the terms and conditions described at <http://www.neptronic.com/Sales-Conditions.aspx>.

Contents

1.	Presentation.....	3
1.1.	Description of accessories supplied with the humidifier	3
1.2.	Humidifier overview	3
1.3.	Numbering system	3
2.	Definition	4
2.1.	Evaporation chamber	4
3.	Characteristics	4
4.	Mechanical installation	5
4.1.	General recommendations	5
4.2.	Positioning.....	5
4.3.	Wall mounting.....	5
5.	Steam output connection	6
5.1.	Typical installation	6
5.2.	General recommendations	6
5.3.	Recommendations for steam distribution piping	7
5.4.	Recommendations for the location of the steam dispersion tube	7
6.	Plumbing connections.....	8
6.1.	Water supply	8
6.2.	Drain connections.....	9
7.	Power supply connections	10
8.	Control diagrams.....	11
8.1.	ON/OFF Humidifier (standard)	11
8.2.	Modulating Humidifier.....	12
9.	Control panel display	13
10.	Description of the control PC Board	14
10.1.	P.C. Board for ON/OFF Humidifier (standard)	14
10.2.	P.C. Board for Modulating Humidifier.....	15
11.	Start up procedure	16
12.	Description of operation of the SKR.....	16
13.	Shut-down procedure.....	17
14.	Maintenance	17
14.1.	General.....	17
14.2.	Evaporation chamber cleaning	17
15.	Exploded View and Bill of Material.....	19
15.1.	Exploded view.....	19
15.2.	Bill of Material	19
16.	Types of alarm	20
17.	Troubleshooting guide	21
18.	Electrical diagram	22
18.1.	ON/OFF Humidifier (standard).....	22
18.2.	Modulating Humidifier	23
18.3.	Modulating humidifier with HRO20	24
18.4.	Modulating humidifier with HRO20 and SHR10 or SHC80	25

1. Presentation

Thank you for choosing a Neptronic® product. You have purchased the best and the most robust humidifier in its category.

1.1. Description of accessories supplied with the humidifier

- 1 steam dispersion tube.
- 1 length of flexible steam hose.
- 2 adjustable collars to attach the steam hose to the steam outlet.
- 1 female fitting and a braided hose to connect the water supply.

1.2. Humidifier overview

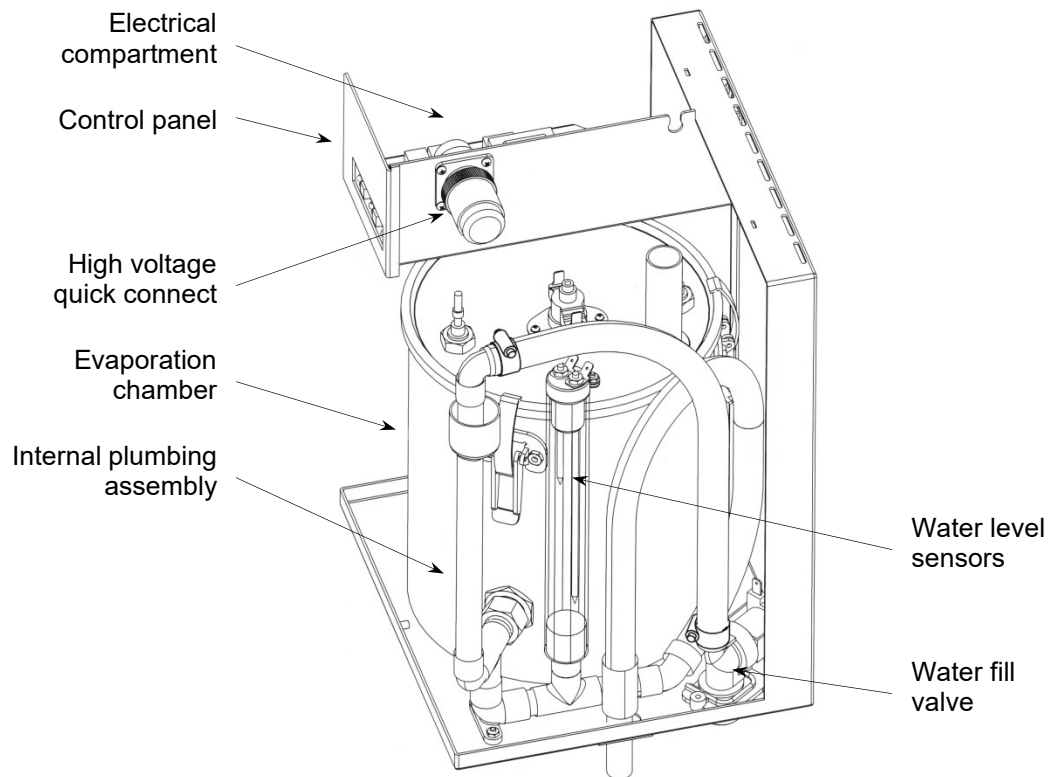

(Fig. 1)

1.3. Numbering system

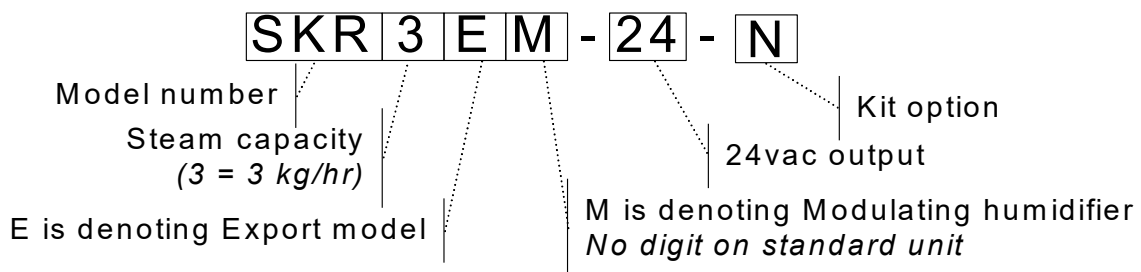

2. Definition

2.1. Evaporation chamber

Assembly including the stainless steel cylinder and a cover equipped with an electric element.

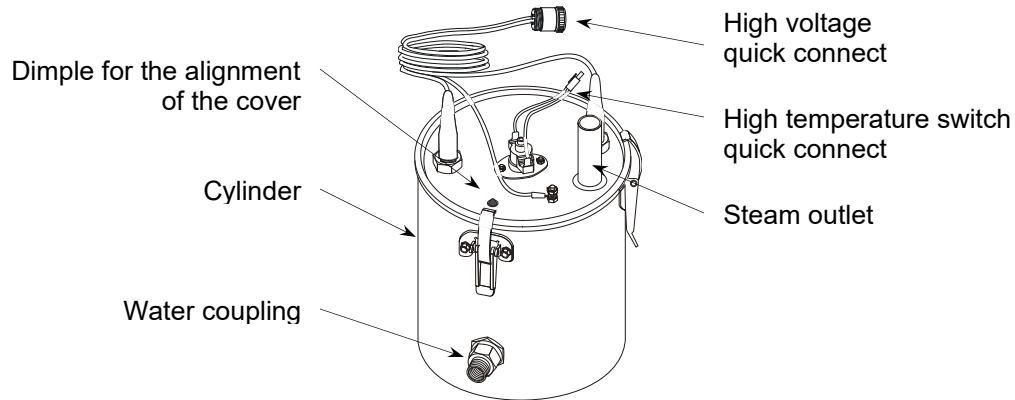

(Fig. 2)

3. Characteristics

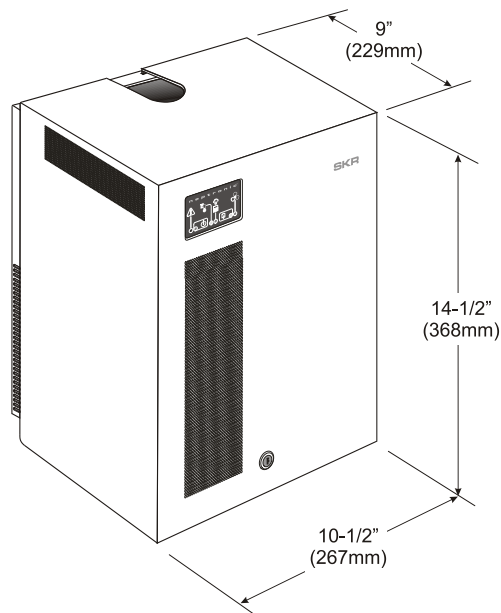

(Fig. 3)

Model	Capacity kg/hr (Lb/hr)	Electrical Requirements			Steam outlet diameter mm (in)	Weight kg (lb)	
		Voltage (V)	Current (A)	Power (KW)		Empty	With water
SKR3E	3.0 (6.6)	230	10	2.3	35 (1-3/8")	10 (22)	16 (35)
SKR4E	3.75 (8.2)	230	12.2	2.8	35 (1-3/8")	10 (22)	16 (35)
SKR5E	5.0 (11.0)	230	16.1	3.7	35 (1-3/8")	10 (22)	16 (35)

4. Mechanical installation

4.1. General recommendations

- **CAUTION: RISK OF ELECTRIC SHOCK. DISCONNECT THE HUMIDIFIER FROM THE ELECTRIC SUPPLY BEFORE PROCEEDING TO THE MECHANICAL INSTALLATION.**
- **IMPORTANT:** Mechanical installation should conform to Local and National Codes.
- Location: Plan a location which is easy to access to permit a proper inspection and servicing of the humidifier.
Do not install humidifier where failure of the appliance could cause damage to the building structure or to costly equipment.
This location should be well ventilated; the ambient temperature should not exceed 30°C (85°F).
- The maximum distance between the humidifier and the steam dispersion tube in the ventilation duct should not exceed 1.8m (6 feet) (maximum length of the steam hose).

4.2. Positioning

- The front panel and the left side (electrical compartment) should be accessible to permit easy servicing of the humidifier. Leave a clearance of 0.91m (36") from the front panel, 0,30m (12") from the left side, 0.15m (6") from the right side and 0.20m (8") above the humidifier.
- The **SKR** humidifier should be mounted 1 to 1,2m (39" to 47po) above floor for the installation of water supply, drain piping and electrical connections.

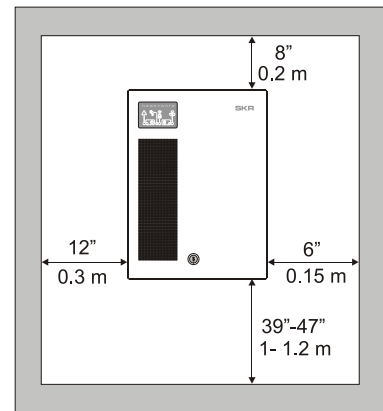

(Fig. 4)

4.3. Wall mounting

- **IMPORTANT:**
 1. **Risk of malfunction. The humidifier must be level.**
 2. **Risk of overheating. Do not block the ventilation openings located on the top, front, sides and rear of the cabinet.**
- Check the solidity of the chosen support or wall (bricks, concrete, stud partition wall, etc.) on which the humidifier will be mounted (see page 4 for the weight of the unit).
- Use the keyholes located on the back panel of the humidifier.
- Drill holes for the upper anchors (holes with eyelets) into the support or wall as per dimensions specified in the table (fig.5). The hole dimensions (diameter and depth) should be in accordance with the recommendations of the chosen anchors.
- If necessary, install bolt anchors.
- Insert the 2 screws (holes with eyelet) of a minimum diameter of 6mm (1/4") (screws are not supplied).
Leave a clearance between screw heads and wall in order to permit the mounting of the humidifier.
- Hang the humidifier on the 2 screws.
- When the humidifier is positioned on the screws, tighten the screws to secure the humidifier.

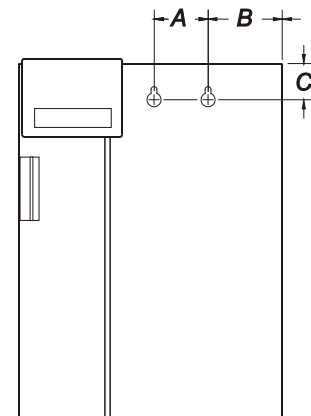

(Fig. 5)
Front view

Model	Dimensions mm (in)		
	A	B	C
SKR	51 (2")	78 (3.06")	37 (1.44")

5. Steam output connection

5.1. Typical installation

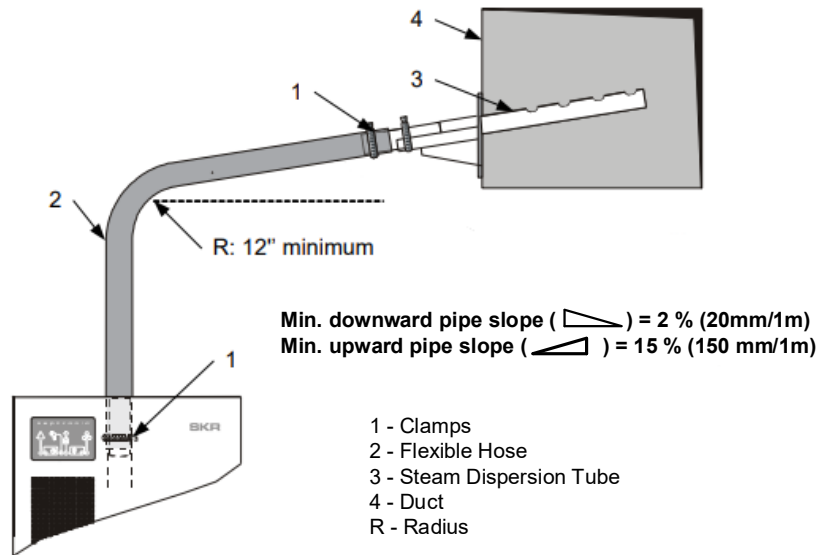

(Fig. 6)

5.2. General recommendations

Follow these general installation rules to avoid any condensation accumulation which can cause severe water accumulation in the duct or a humidifier malfunction.

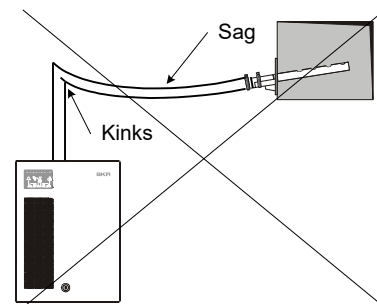

IMPORTANT: Risk of malfunction. Avoid kinks, sags and areas where condensate can become trapped.

- Ensure that the minimum steam pipe gradient must be 2% downward and 15% upward, i.e., 20 mm per 1 m run and 150 mm per 1 m run to ensure continuous drainage of condensate back to the humidifier or to a steam trap.
- The lowest point of any steam hose or rigid pipe must be the humidifier (fig.7b).** If the humidifier cannot be the lowest point of the piping, install a steam trap(s) (S Type) at the lowest point(s) of the steam supply piping (fig.7c). This trap should have a minimum height of 76mm (3").
- Total length of the steam hose or rigid pipe should not exceed 1,8 meters (6 feet).** Longer runs will result in added condensation losses and may result in system malfunction. Minimum radius of any change of direction should be 307mm (12"). A maximum of 2 long radius elbows (307mm) are to be used on the steam distribution line.
- Whenever using rigid copper pipe, use insulation to diminish condensate build up.



(Fig. 7a)

Incorrect installation

Min. downward pipe slope () = 2 % (20mm/1m)
 Min. upward pipe slope () = 15 % (150 mm/1m)

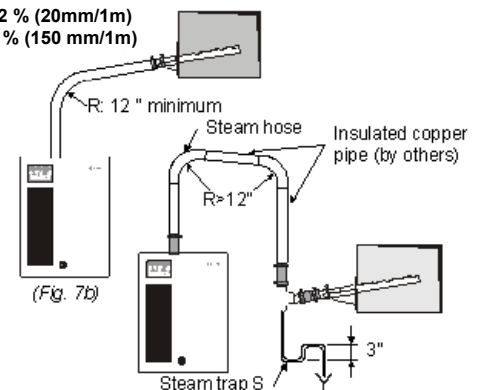

(Fig. 7b)

(Fig. 7c)

Correct installations



5.3. Recommendations for steam distribution piping

Model	Steam outlet		Steam dispersion tube	MAXIMUM allowable duct static pressure at dispersion tube location Pa (in. water)
	Qty	Diameter mm (in)	Length mm (in)	
SKR-14 / 25	1	35 (1-3/8")	229 (9")	125 (0.5")
SKR-30 / 40	1	35 (1-3/8")	356 (14")	125 (0.5")

IMPORTANT: RISK OF MALFUNCTION. THE STATIC PRESSURE AT THE DISPERSION TUBE LOCATION SHOULD NOT BE GREATER THAN 125 Pa (0.5") DURING OPERATION. FAILURE TO DO SO WILL VOID THE WARRANTY.

For a higher static pressure, use the Neptronic® SKE4 commercial series humidifier.

5.4. Recommendations for the location of the steam dispersion tube

- **IMPORTANT: Risk of malfunction.**
 1. Do not split the steam output piping to supply more than one duct.
 2. Do not reduce the diameter of the steam hose or piping. Hose and piping diameter must be the same as the diameter of the humidifier steam outlet.
- Provide a **minimum of 460mm (18")** of straight duct, without obstructions or elbows, downstream of the dispersion tube.
- Select an accessible location in the supply air duct.
- Use a template and drill a 51mm (2") hole of in the supply air duct for the installation of the of 35mm diameter dispersion tube.
- Secure the dispersion tube bracket to the duct using sheet metal screws (not included).
- In a vertical duct installation, the holes of the dispersion pipe should be aligned with the air flow (see fig. 8d & 8e below).

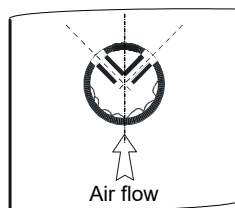
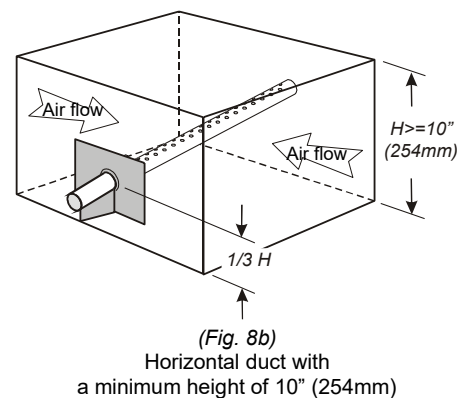
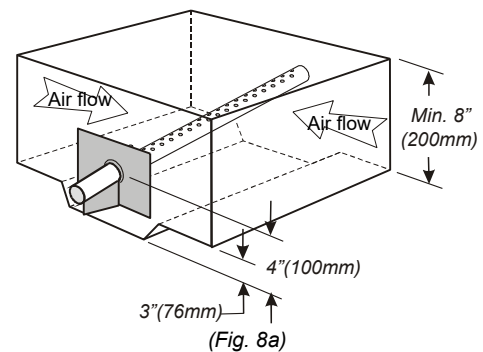

Alignment of dispersion pipe in a vertical duct for the SKR-3E

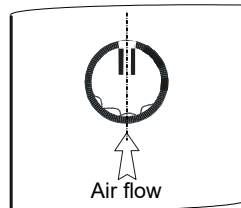

Alignment of dispersion pipe in a vertical duct for the SKR-4E/5E

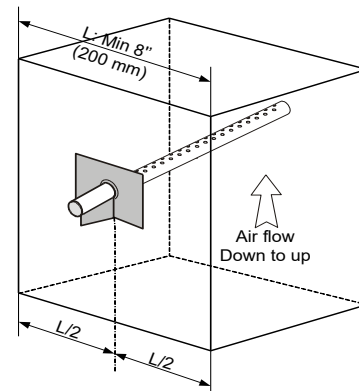

Mounting of the dispersion tube in a vertical duct

6. Plumbing connections

The **SKR** humidifier can operate with soft or hard water. Therefore, for normal operation, no pre-treatment of water is necessary.

IMPORTANT: Plumbing installation should conform to Local and National Codes.

6.1. Water supply

- Water inlet specifications:
 - ✓ **IMPORTANT: Risk of malfunction, do not use demineralized water.**
 - ✓ Inlet water pressure: 1 to 4,8 bars (15 to 70 psig)
IMPORTANT: Risk of malfunction. Do not reduce water supply flow.
 - ✓ Maximum temperature: 30°C (85°F)
 - ✓ 15mm (1/2") standard copper supply water connection
- To facilitate servicing, a shut off valve (not supplied) should be installed in the water supply line, close to the humidifier.
- It is recommended to install a standard strainer in the water supply line.
- It is recommended to install a water hammer arrestor to absorb the hydraulic shock and minimize the water hammer when the fill valve closes. Follow the dimensioning and installation in accordance with the local plumbing code.

Please follow the steps below:

1. Connect 15mm (1/2") copper pipe to the 15mm (1/2") braided hose (supplied).
2. Hand tighten the swivel top 20mm (3/4") fitting to the male threaded valve connection.
IMPORTANT: Risk of damage to the valve, do not use wrench to tighten swivel.

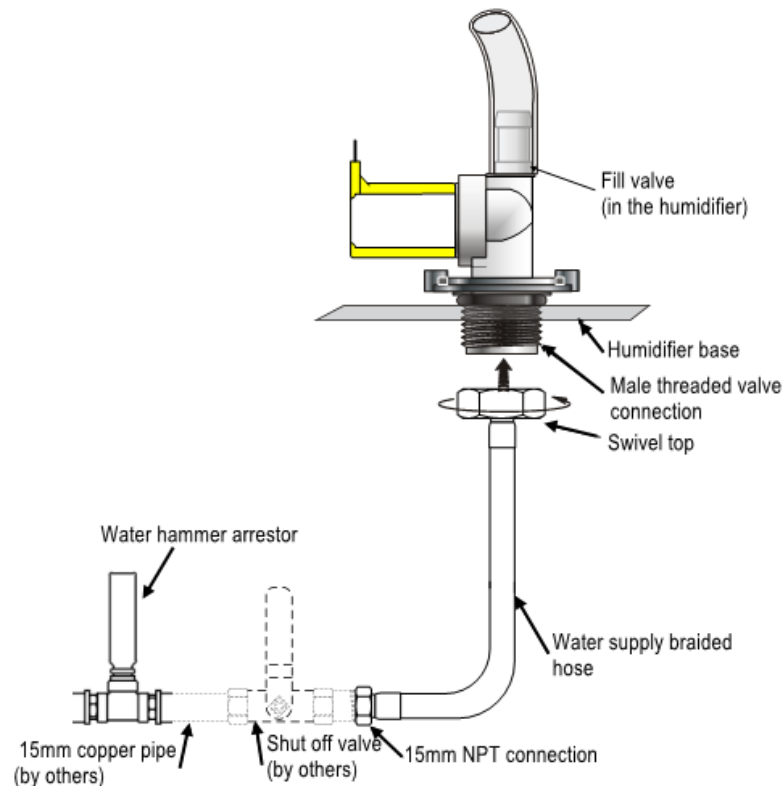

(Fig. 9)



6.2. Drain connections

- **IMPORTANT: No external drain traps are required.**
- Drain outlet specification:
 - ✓ Main drain 15mm (1/2") standard copper (evaporation chamber).
 - ✓ Pan drain 15mm (1/2") standard copper.
 - ✓ Water drain temperature: 60°C (140°F).
- **Two pipes minimum 25mm (1")** (by others) must be inserted over the humidifier outlet pipes (fig.10). This will create a critical air gap at the drain connections.
NOTE: This air gap is critical for normal drain siphon operation.

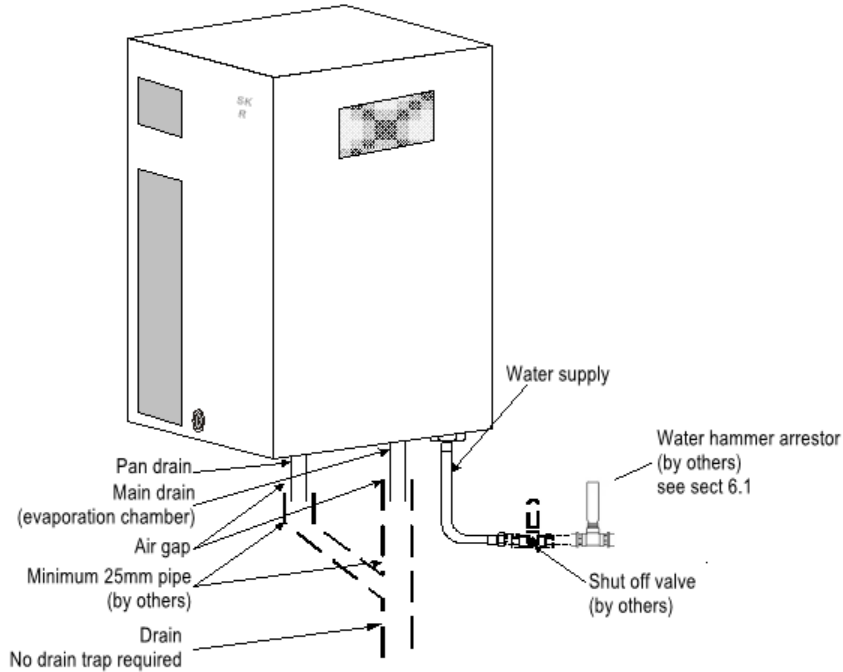

(Fig. 10a)
Correct installation

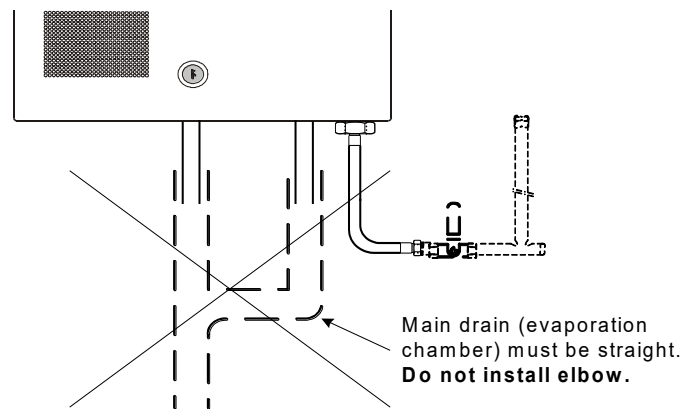

(Fig. 10b)
Incorrect installation

7. Power supply connections

- **CAUTION:**
 1. **RISK OF ELECTRIC SHOCK, TURN OFF POWER AT THE EXTERNAL BREAKER/FUSED DISCONNECT BEFORE PROCEEDING TO THE POWER SUPPLY CONNECTION.**
 2. **To reduce the risk of electric shock, do not connect to a circuit operating at more than 150V to ground.**
- **IMPORTANT:** The wiring to the humidifier should be done by a qualified electrician and conform to procedures, regulations and local codes.
- Ensure that the voltage required by the humidifier is the same as the available power supply.
- Ensure that the size of the wire conductors is appropriate for the current required by the humidifier.
- A dedicated external breaker/fused disconnect must be installed.
- The ground conductor must be equipped with ring terminal and be connected the indicated location (fig.11).
- Use coppers conductors only.
- Ensure that each terminal connection is properly secured.
- Install the supplied strain relief bushing at the bottom of the electrical compartment for of the supply cable.

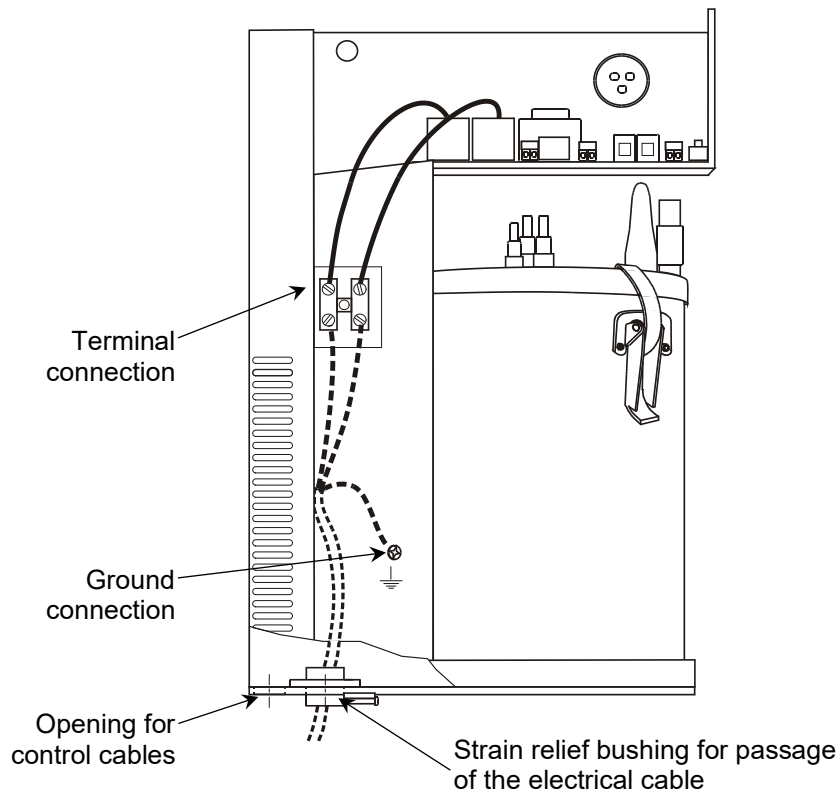

(Fig. 11)
 Left side view

8. Control diagrams

IMPORTANT:

1 - Risk of malfunction. Do not supply power from external source to control terminals TB4 and TB5. These terminals are powered by the humidifier.

2 - Maximum length of each control cable is 250 feet (76m).

8.1. ON/OFF Humidifier (standard)

- ✓ Wire humidistat or Building Automation System signal to close on humidity drop below set point.
- ✓ Wire airflow switch to close when sensing air flow and open when no air flow is sensed.
- ✓ Wire high limit humidistat to close on drop in humidity and to open when set point is reached.

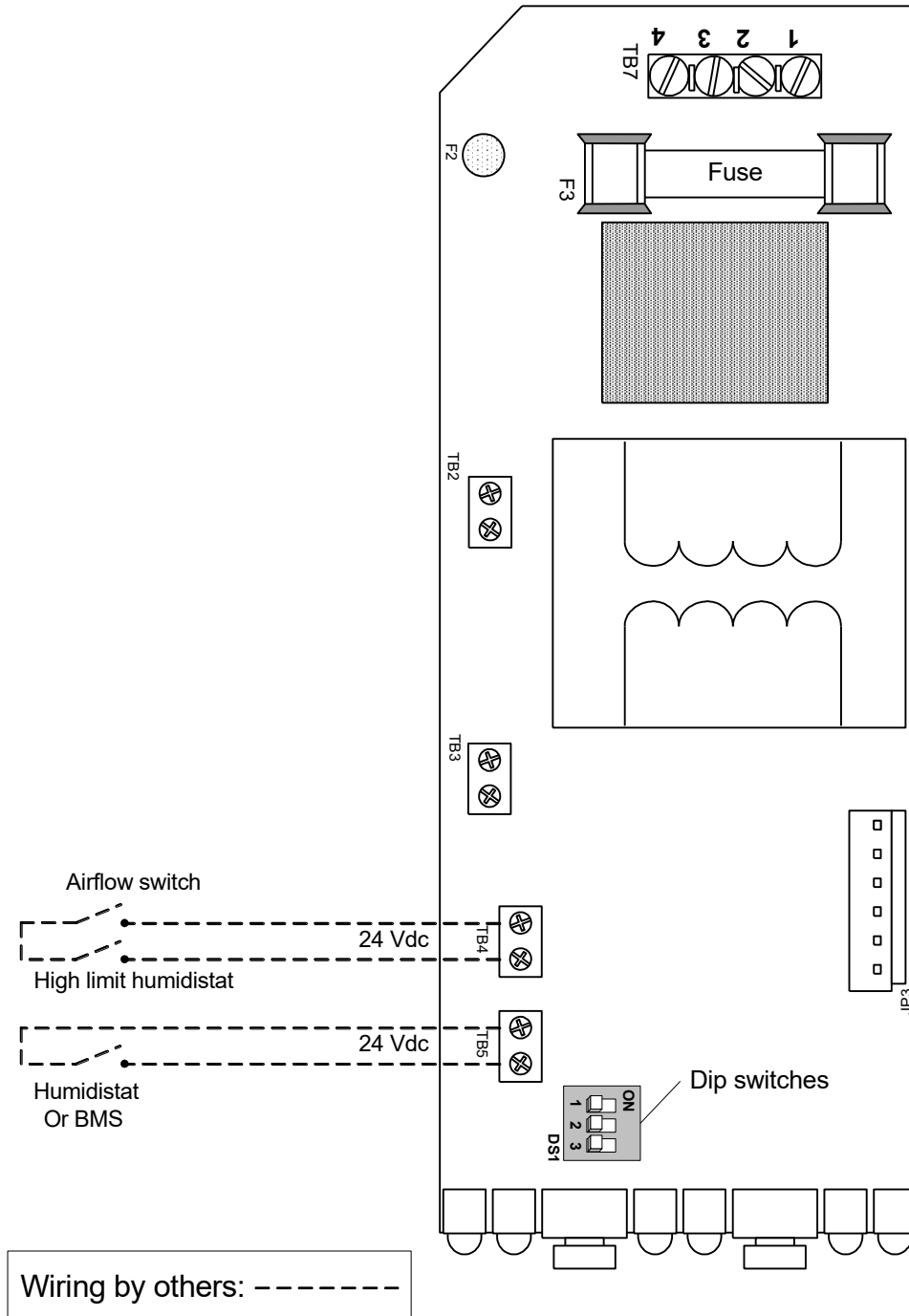

(Fig. 12a)



8.2. Modulating Humidifier

- ✓ Wire humidistat or Building Automation System signal to modulate steam output.
- ✓ Wire airflow switch to close when sensing air flow and open when no air flow is sensed.
- ✓ Wire high limit humidistat to close on drop in humidity and to open when set point is reached.
- ✓ Wire external cut-out, if required, to remotely switch off humidifier.

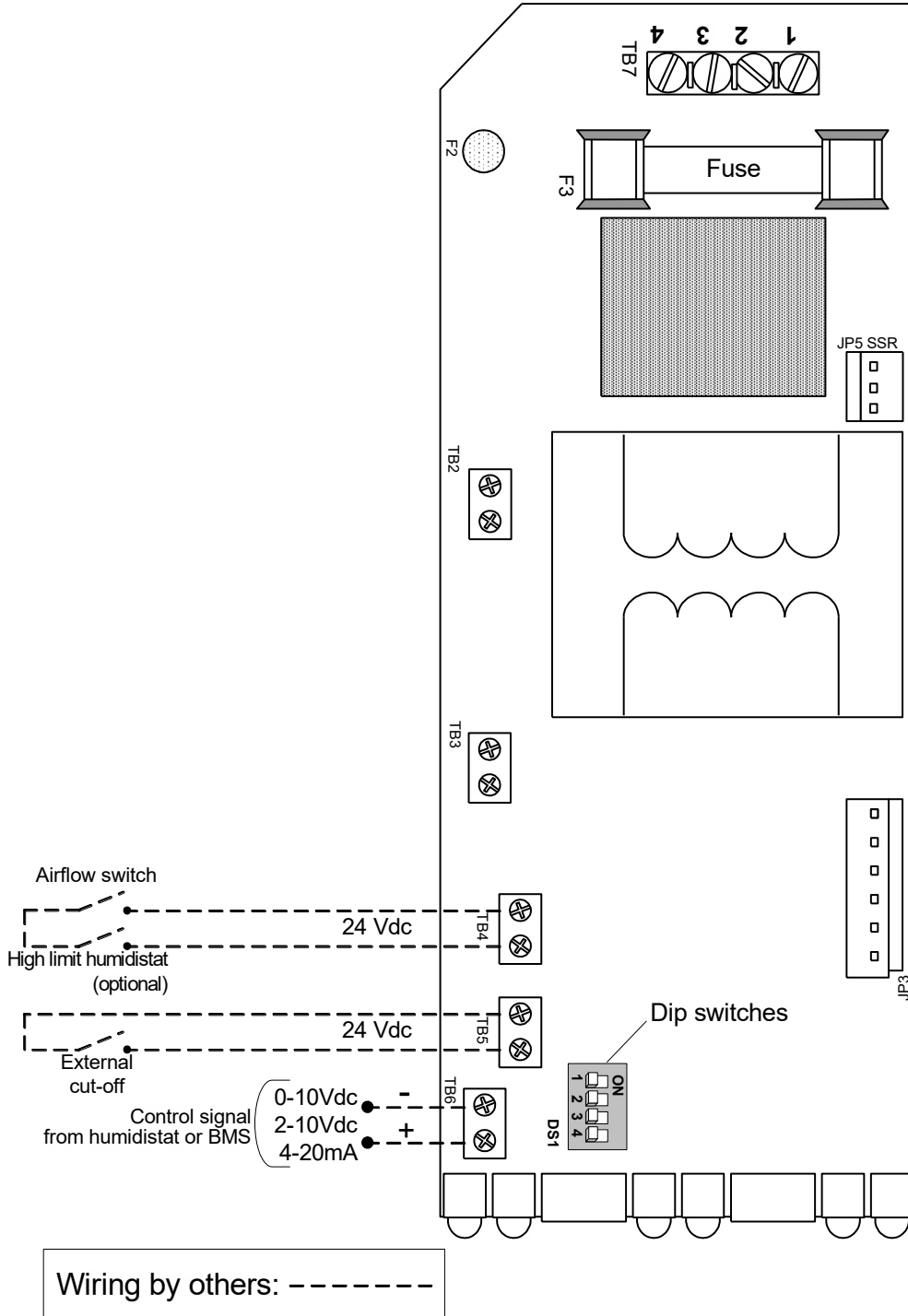

(Fig. 12b)

9. Control panel display

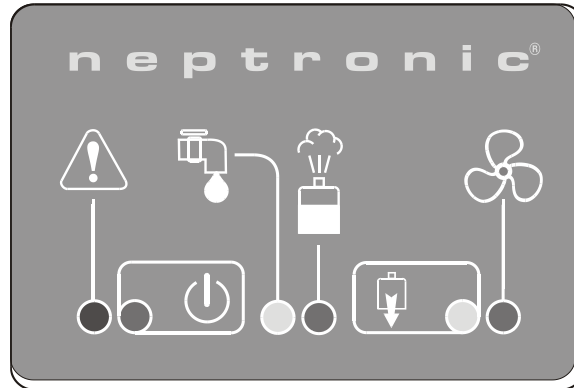

(Fig. 13)
Front panel



"ALARM" Indicator (red)

⊃○⊂ flashing	One or more abnormal conditions exist. (see section 16-Types of alarm)
⊃○⊂	Maintenance is required, the humidifier is OFF.
○	Normal operation.



"POWER" Push button and Indicator (green)

⊃○⊂	The push button is in the ON position.
⊃○⊂ slow flashing	The push button is in the OFF position and the humidifier is powered. (1 flash every 15 seconds).
○	Humidifier is not supplied with electric power.



"FILL" Indicator (yellow)

⊃○⊂	Water supply valve is open.
○	Water supply valve is closed.



"STEAM" Indicator (green)

⊃○⊂	Humidifier is producing steam at 100% capacity
⊃○⊂ flashing	Modulating humidifier only: Humidifier is modulating steam output according to the demand. Frequency of flashing is in proportion to the percentage of steam output.
○	Humidifier is not producing steam.



"DRAIN" Push button and Indicator (yellow)

⊃○⊂	Humidifier is in automatic or manual drain mode. <i>Press "DRAIN" push button to stop an on-going drain cycle.</i>
○	Drain mode is off.



"FAN" Indicator (green)

⊃○⊂	The contact to activate the ventilation system fan is closed.
○	The contact to activate the ventilation system fan is open.

10. Description of the control PC Board

The Printed Circuit Board is equipped with an advanced microprocessor, which controls all humidifier functions.

10.1. P.C. Board for ON/OFF Humidifier (standard)

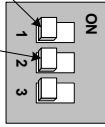
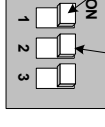
TB2	Dry contact (TB2) to connect to fan relay in order to activate the ventilation system fan on call for humidity (3amp, 24Vac).
TB3	Dry contact (TB3) for remote alarm annunciation (1amp, 24Vac).
TB4	Terminal to connect the airflow proving switch and the high limit humidistat (see fig.12a)
TB5	Terminal to connect the humidistat or Building Automation System (see fig.12a).
DS1	<p>Dip switches (DS1) setting:</p> <p>Drain every 2 hours of operation</p> <p>"Service required" alarm appear after 750 hours of operation</p>  <p>Drain every 6 hours of operation</p> <p>"Service required" alarm appear after 1500 hours of operation</p>  <p>(Fig 14b) Dip switch setting</p> <p>DS1-3 : Dip switch is not used</p> <p>Note: Depending on the local water conditions, service of the humidifier may be required prior to the "service required" alarm setting (see section 14, Maintenance).</p>

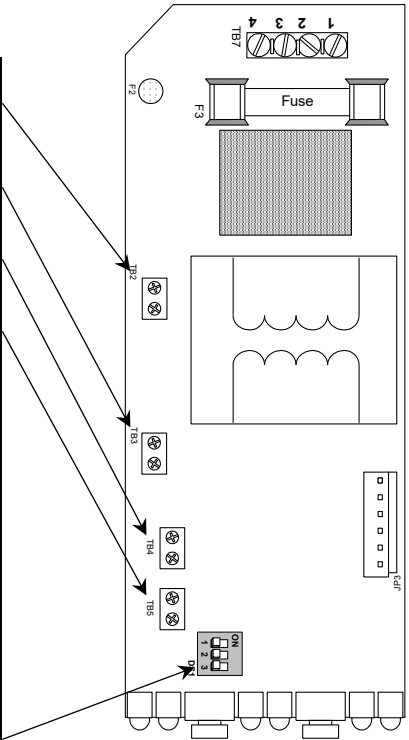

(Fig. 14a)
Top view

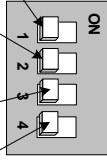
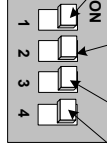

10.2. P.C. Board for Modulating Humidifier

TB2	Dry contact (TB2) to connect to fan relay in order to activate the ventilation system fan on call for humidity (3amp, 24Vac).
TB3	Dry contact (TB3) for remote alarm annunciation (1amp, 24Vac).
TB4	Terminal to connect the airflow proving switch and the high limit humidistat (see fig. 12a)
TB5	Terminal to connect humidifier external cut-off.
TB6	Terminal to connect the humidistat or Building Automation System (see fig. 12b)
DS1	<p>Dip switches (DS1) setting:</p> <p>Drain every 2 hours of operation</p> <p>"Service required" alarm appear after 750 hours of operation</p> <p>No function attributed</p> <p>2-10 VDC control demand signal</p>  <p>Drain every 6 hours of operation</p> <p>"Service required" alarm appear after 1500 hours of operation</p> <p>No function attributed</p> <p>0-10 VDC control demand signal</p>  <p>(Fig 15b) Dip switch setting</p> <p>DS1-3 : Dip switch is not used</p> <p>DS1-4: For 4-20mA input signal, set the dip switch to the OFF position and connect the supplied 500 ohm resistor between the + and – of the terminal block TB6.</p> <p>Note: Depending on the local water conditions, service of the humidifier may be required prior to the "service required" alarm setting (see section 14, Maintenance).</p>

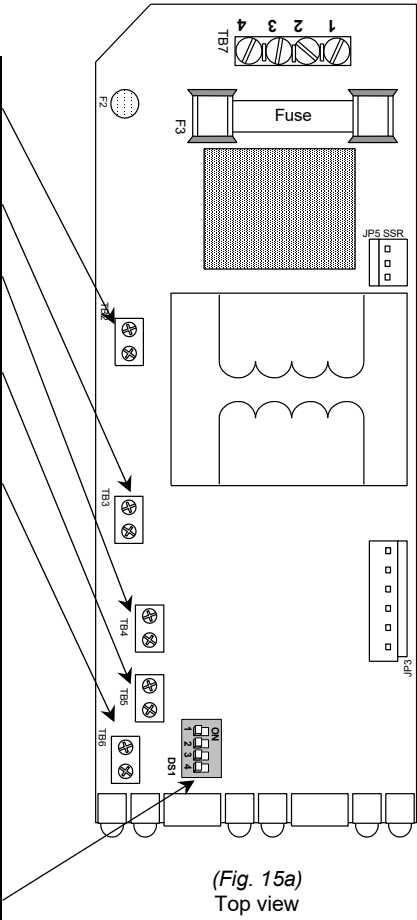



11. Start up procedure

Follow this start-up procedure to avoid improper system operation:

1. Ensure that steam distribution, electrical and plumbing connections have been done in accordance with the instructions in this manual.
 - a) Remove the humidifier cover.

CAUTION: RISK OF ELECTRIC SHOCK, ENSURE THAT THE POWER IS TURNED OFF BEFORE REMOVING THE COVER.
 - b) Ensure that the control wiring has been made in accordance with the instructions in this manual.
 - c) Ensure that dip switches (section 10, DS1) are correctly set.
 - d) Verify that the drain connections are connected to an open main drain of sufficient diameter.
 - e) Re-install the humidifier cover.
2. Open the water shut off valve (external to the humidifier).
3. Turn on the power to the humidifier at the breaker/fused disconnect. The "**POWER**" indicator, located on the control panel, will flash.
4. Press the "**POWER**" push button located on the control panel. The "**POWER**" indicator will stay on continuously.
5. Perform a manual cleaning cycle:
 - a) The fill cycle is activated automatically when the evaporation chamber does not contain water.
 - b) When the "**FILL**" indicator is off, press the "**DRAIN**" push button.
 - c) The "**DRAIN**" indicator will come on and the water will drain from the evaporation chamber.
 - d) The evaporation chamber will fill with water and drain again.
 - e) When the "**DRAIN**" indicator turns off, press on the "**POWER**" push button.
 - f) Repeat steps "b" through "e" one more time to ensure proper cleaning of the evaporation chamber.
6. Your humidifier is now fully operational. No other action is necessary; your **SKR** humidifier will produce steam upon demand from control(s).

12. Description of operation of the SKR

- Press the "**POWER**" push button (if the indicator is flashing) to start the humidifier ("**POWER**" indicator will light continuously). If the evaporation chamber does not contain water, the fill cycle is activated automatically ("**FILL**" indicator is on).
- If there is no demand from the humidity controller, the humidifier is in a standby mode ("**STEAM**" indicator is off).
- On a demand of humidity, the contact to activate the ventilation system fan closes ("**FAN**" indicator is on) and the relays close to power the electric element in the evaporation chamber ("**STEAM**" indicator is on).
- The water in the evaporation chamber will start to boil and evaporate. The steam is released through the opening in the cover of the evaporation chamber. The steam will travel in the flexible steam hose and disperse inside the supply duct through the steam dispersion tube.
- During the evaporation sequence, a certain amount of water is evaporated. The water supply valve will open to replenish the water in the evaporation chamber.
- Depending on the selected drain period (section 10, DS1-1), the water in the evaporation chamber will be drained ("**DRAIN**" indicator is on) to renew the water and to evacuate the minerals inside the evaporation chamber.
- The **SKR** operates at full capacity until the programmed humidity level set point is reached. When the set point is reached, the humidifier will revert to standby mode. The contact to activate the ventilation system fan (section 10, TB-5) will remain closed for a period of four minutes after steam production has stopped.
- When the humidity level is below the set point, the humidifier will produce steam again. If there is no humidity demand for a period of more than 72 hours, the humidifier will drain the water from the evaporation chambers automatically and go into standby mode.

13. Shut-down procedure

During seasonal shut down, the humidifier should be placed out of service.

1. Press "**DRAIN**" push button to empty the water from the evaporation chamber, the "**DRAIN**" indicator will be on.
2. Once the cycle has ended, the "**DRAIN**" indicator will turn off. Close the shut off valve (external to the humidifier) on the water supply line.
3. Open the main power breaker/fused disconnect switch to the humidifier.

14. Maintenance

14.1. General

- **IMPORTANT:** Failure to perform the required periodic maintenance will void the warranty.
- The required cleaning frequency can vary from every 2 months to once a year depending on local water conditions.
- The **SKR** humidifier is equipped with an internal operating hour counter and a "service required" alarm. Depending on the local water conditions, service of the humidifier may be required prior to the "service required" alarm setting (section 10, DS1-2).
- The routine service is a cleaning of the evaporation chamber.

14.2. Evaporation chamber cleaning

CAUTION: RISK OF BURN. THE EVAPORATION CHAMBER AND ITS CONTENTS CAN BE EXTREMELY HOT, CHECK TEMPERATURE BEFORE HANDLING.

1. Cooling down and draining of the evaporation chamber.

- a) Press "**DRAIN**" push button on the control panel. The humidifier will initiate a drain cycle. The "**DRAIN**" indicator will turn on.
- b) The "**DRAIN**" indicator is on and the water is drained from the evaporation chamber.
- c) The evaporation chamber will refill with water and drain again.
- d) When the "**DRAIN**" indicator turns off, the "**POWER**" indicator will begin to flash.
- e) Check the temperature of the evaporation chamber. If it is cool enough go to step #2 below, otherwise repeat draining of the evaporation chamber (step #1) until is cold enough.

2. Shut down of the electrical supply.

CAUTION: RISK OF ELECTRIC SHOCK, TURN OFF POWER AT THE EXTERNAL BREAKER/FUSED DISCONNECT BEFORE SERVICING.

- a) Remove the cover of the **SKR** Humidifier.

3. Disconnecting the heating element.

- a) Unscrew the high voltage quick connect (see fig.2), located on the right side of the electrical compartment.

4. Disconnecting the high temperature switch.

- a) Disconnect the high temperature switch quick connect (see fig.2).

5. Disconnecting the steam hose and the water pipe.

- a) Loosen clamp on the steam hose connection.
- b) Remove the steam hose from the top of the evaporation chamber.
- c) Unscrew the water piping coupling located on the lower right hand side of the evaporation chamber.

6. Removing the evaporation chamber.

- a) Remove the evaporation chamber from the humidifier cabinet.



7. Opening the evaporation chamber.

- a) Unfasten the 3 latches located around the evaporation chamber.

Caution: Risk of injury, latches are tight. It is recommended to use pliers or a screwdriver to unfasten the latches.

- b) Remove the cover from the evaporation chamber.
- c) Do not misplace the gasket located between the cover and the cylinder.

8. Cleaning the evaporation chamber.

- a) Pour out any remaining water and scale from the bottom of the evaporation chamber
- b) Clean out the remaining scale, use a non-metallic brush and water. Some vinegar or any weak acid for cleaning stainless steel may be required.

IMPORTANT: The use of wire brush or any non-recommended acid will void the warranty.

- c) If the amount of scale to be removed is significant, the service required alarm setting and/or the drain rate (section 10, DS1) may be set too high for the local water conditions. Too much scale may impair the normal operation of the humidifier or damage it. In this case, increase the frequency of maintenance as necessary.

9. Cleaning the electric element and cover.

- a) The cover of the evaporation chamber and element will, in general, not require cleaning. However, if cleaning is required, proceed as per the cleaning of the evaporation chamber.

IMPORTANT: The use of wire brush or any non-recommended acid will void the warranty.

10. Checking the gasket

- a) Check the gasket. The gasket should not be cracked.
The gasket must be replaced a minimum at every second maintenance of the evaporation chamber or after one year of operation. Replace more frequently if required.

11. Reassembling the evaporation chamber.

- a) Rinse out the cylinder and the cover with water.
- b) Place the gasket inside the cover before installing the cover on the evaporation chamber.
- c) Align the dimple on the cover with the latch located nearest to the water drain/fill coupling (fig.2).
- d) Tighten the three latches around the cover.
- e) Replace the evaporation chamber in the humidifier.
- f) Tighten the water drain/fill coupling.
- g) Replace the steam hose on the outlet of the evaporation chamber and secure steam hose with the clamp.
- h) Reconnect the high temperature switch connector and the high voltage connector of the heating element.

CAUTION: RISK OF OVERHEAT AND FIRE, MAKE SURE THE HIGH VOLTAGE CONNECTOR IS PROPERLY LOCKED.

- i) Replace the cover on to the humidifier and lock it.

12. Start-up of the humidifier.

- a) Close the main power breaker/fused disconnect switch to the humidifier.

Reset of the operating hours to zero: Press "POWER" push button to turn OFF the humidifier, if necessary, then press and hold the "POWER" and "DRAIN" push buttons for ten seconds (section 16-Types of alarm, Reset).

- b) Press the "POWER" push button. The "POWER" indicator on the control panel will light.
- c) The humidifier will go into a fill cycle; the "FILL" indicator will be on.
- d) If there is a humidity demand, the humidifier will produce steam.

15. Exploded View and Bill of Material

15.1. Exploded view

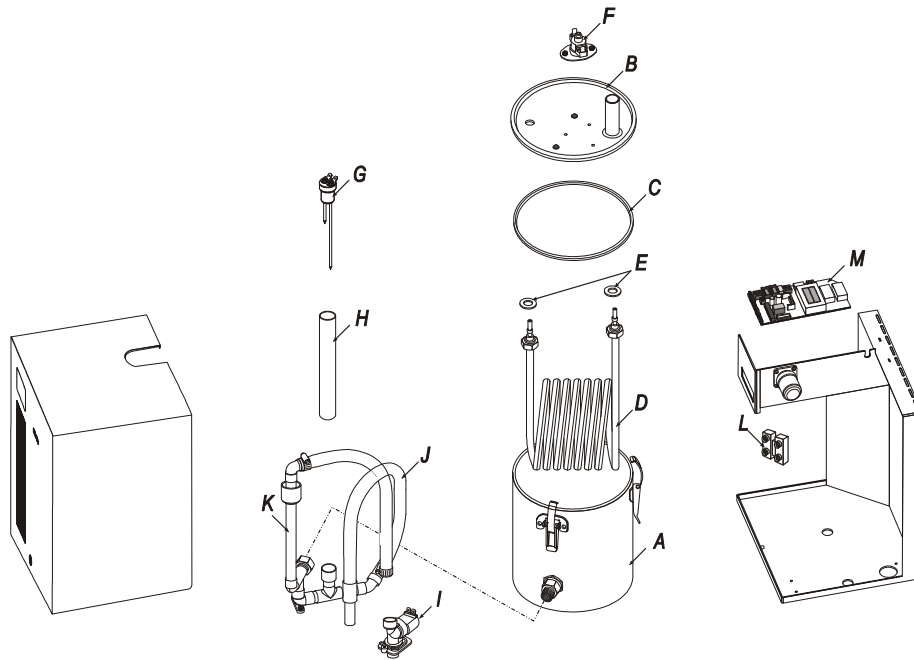

(Fig. 16)

15.2. Bill of Material

Item	Description	Model	Part number
A	Evaporation chamber cylinder	SKR 3E / 4E / 5E	SW SKRCONT-ASSY
B	Evaporation chamber cover	SKR3E	SP 9011
		SKR 4E / 5E	SP 9012-M
C	Evaporation chamber gasket	SKR 3E / 4E / 5E	SP 9030
D	Heating element	SKR3E	SE 5991
		SKR4E	SE 5992
		SKR5E	SE 5993
E	Heating element gasket	SKR 3E / 4E / 5E	SP 1005
F	High temperature switch	SKR 3E / 4E / 5E	SP 3035
G	Water level sensor assembly	SKR 3E / 4E / 5E	SW SKRLEV-ASSY
H	Water level sensor tube	SKR 3E / 4E / 5E	SP 1025
I	Water fill valve	SKR 3E / 4E / 5E	SP 6004
J	Drain pipe assembly	SKR 3E / 4E / 5E	SW SKRDRAIN-ASSY
K	Main plumbing assembly	SKR 3E / 4E / 5E	SW SKRPIPE-ASSY
L	Terminal block	SKR 3E / 4E / 5E	SP 9046
M	Main PC board - ON/OFF	SKR 3E / 4E / 5E	NW SKRE-24-NSS
	Main PC board – Modulating	SKR 3EM / 4EM / 5EM	NW SKRE-M24-NSS
N	Solid State Relay (Not Shown)	SKR 3EM / 4EM / 5EM	SP 3102
O	Cooling Fan (Not Shown)	SKR 3EM / 4EM / 5EM	SP 9017

16. Types of alarm

CAUTION: RISK OF ELECTRIC SHOCK, POWER MUST BE TURNED OFF AT THE EXTERNAL BREAKER/FUSED DISCONNECT BEFORE REMOVING THE COVER OF THE HUMIDIFIER.

- **IMPORTANT:** A corrective action must be taken before doing a reset.
- The alarm contact (normally open) will close when there is an alarm.

ALARM Indicator	Condition	Consequences	Corrective actions	Reset
Service required 1. Flashing continuously	Operating hours exceeded the service required alarm hour setting (DS1-2)	Alarm. No interruption of the operation of the humidifier	Proceed to a service (See section 14-Maintenance)	<ul style="list-style-type: none"> • Press the "POWER" push button to turn OFF the humidifier (if necessary). • Press and hold "DRAIN" and "POWER" push buttons simultaneously for ten seconds. These two indicators will turn on after the ten seconds. Release the push buttons.
Service required 2. Indicator is continuously on <i>(SKR Humidifier shut off)</i>	Operating hours exceeded by more than 50 hours the service required alarm setting (DS1-2)	Alarm. The operation of the humidifier is interrupted	Proceed to a service See section 14-Maintenance)	
High temperature 2 flashes + pause	Temperature in the evaporation chamber exceeded the preset temperature of the high temperature switch	Alarm. The operation of the humidifier is interrupted	<ul style="list-style-type: none"> • Check that the static pressure inside the duct at the steam dispersion tube does not exceed 125Pa. (0.5" W.G). • Check that the steam hose is not blocked or kinked. • Check that the water connection on the evaporation chamber is not blocked. 	Press the reset button on the high temperature switch device located on the evaporation chamber cover.
Drainage 3 flashes + pause	Drainage sequence is not correct	Alarm. The operation of the humidifier is interrupted	<ul style="list-style-type: none"> • Check that the water connection to the evaporation chamber is not blocked. • Check that the drain piping is not blocked. 	Press on the DRAIN push button
Fill 4 flashes + pause	Time to fill the evaporation chamber exceeded the preset time in the microprocessor	Alarm. The power to the heating element is interrupted	<ul style="list-style-type: none"> • Check that the shut off valve installed on the supply water line is open. • Verify the operation of the fill valve. • Check that the fill valve strainer and the external strainer are not blocked. 	Automatic reset when the proper water level is reached
Level sensors 5 flashes + pause	The level sensors do not detect the water level correctly	Alarm. The operation of the humidifier is interrupted	<ul style="list-style-type: none"> • Check that the sensors are properly connected. • Check that the sensors are clean. 	Press on the POWER push button
Power Not flashing	The unit is not powered	–	<ul style="list-style-type: none"> • Check that the main power breaker or fused disconnect switch is closed 	Automatic reset when the unit is powered

17. Troubleshooting guide

Problem	Causes	Corrective actions
The humidifier does not operate (no alarm)	<ul style="list-style-type: none"> • The humidifier is not powered. • Airflow is not detected by the airflow proving switch. • Ventilation system fan is not operating. • The airflow proving switch is not detected or not operational. • The high limit duct humidistat is not operational (if available). 	<ul style="list-style-type: none"> • Check for the main power supply and fuses. • Check that the sensor tube is connected properly inside the duct and to the airflow switch. • Check that the airflow switch and the high limit duct humidistat (if available) are located properly. • Check the fan operation.
The humidifier does not operate (alarm indicator flashing)	<ul style="list-style-type: none"> • Check the alarm indicator to determine the cause 	<ul style="list-style-type: none"> • See section 16-Types of alarm to correct the situation
The duct downstream of the dispersion tube is wet	<ul style="list-style-type: none"> • The installation of the steam dispersion tube is incorrect. • The capacity of the humidifier is too high. • The high limit humidistat is not installed properly or is defective (if available). 	<ul style="list-style-type: none"> • Check if the steam dispersion tube is installed correctly. • Install a high limit duct humidistat if required. • Verify the installation and the operation of the high limit duct humidistat (if available).
Water accumulation under the humidifier	<ul style="list-style-type: none"> • The drain pipes are leaking, are obstructed or the slope is incorrect. • A drain trap is installed on the drain line. • The water supply connection is leaking. • The installation of the flexible steam hose is incorrect. • Evaporation chamber is leaking steam. 	<ul style="list-style-type: none"> • Check all the couplings and drains under the unit. • Remove all drain traps. • Check water supply circuit. • Check that the clamp on the steam hose is properly tightened on the steam outlet of the evaporation chamber. • Check the condition of the evaporation chamber gasket inside the evaporation cover.

18. Electrical diagram

18.1. ON/OFF Humidifier (standard)

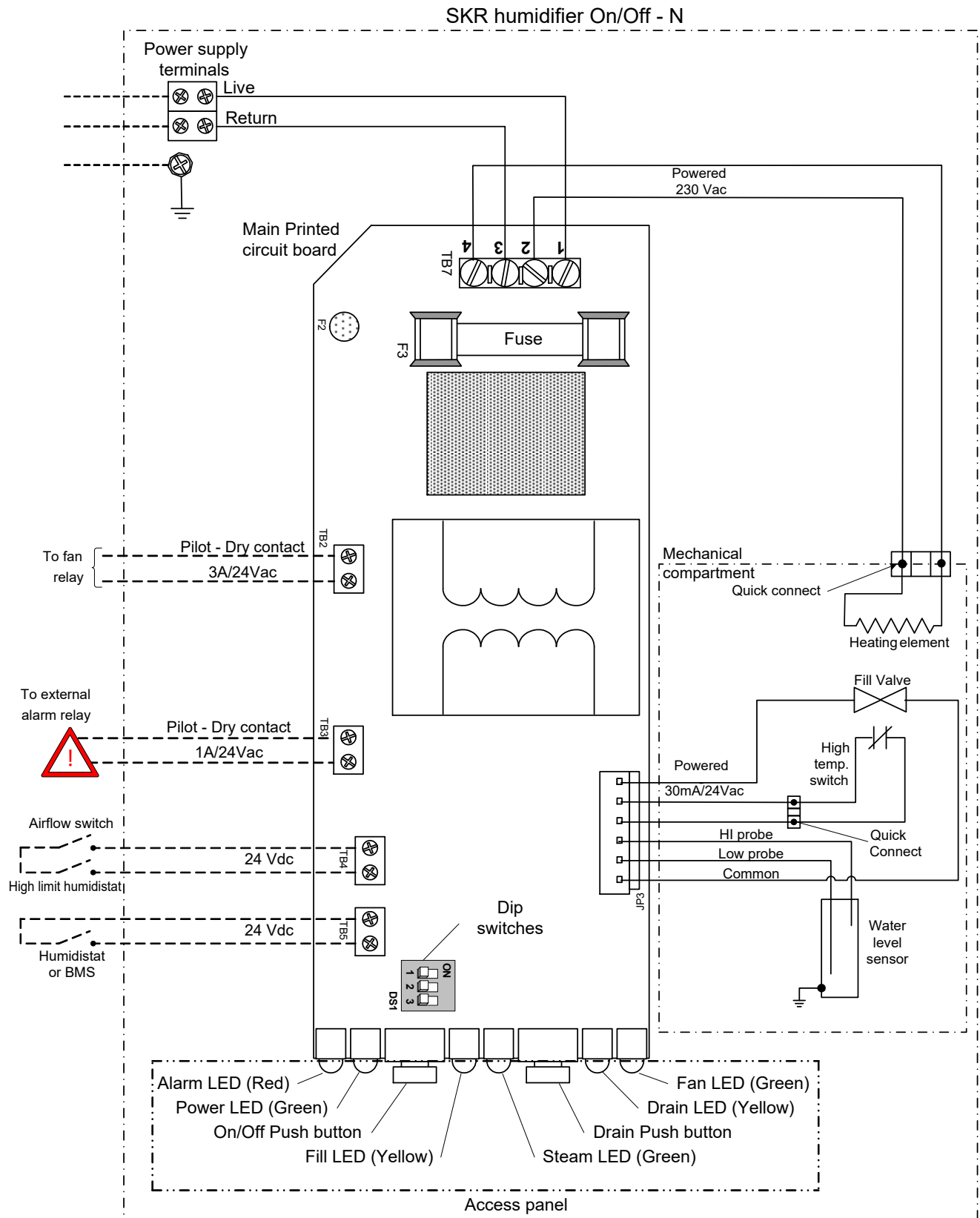

(Fig. 17a)

18.2. Modulating Humidifier

SKR humidifier modulating - N

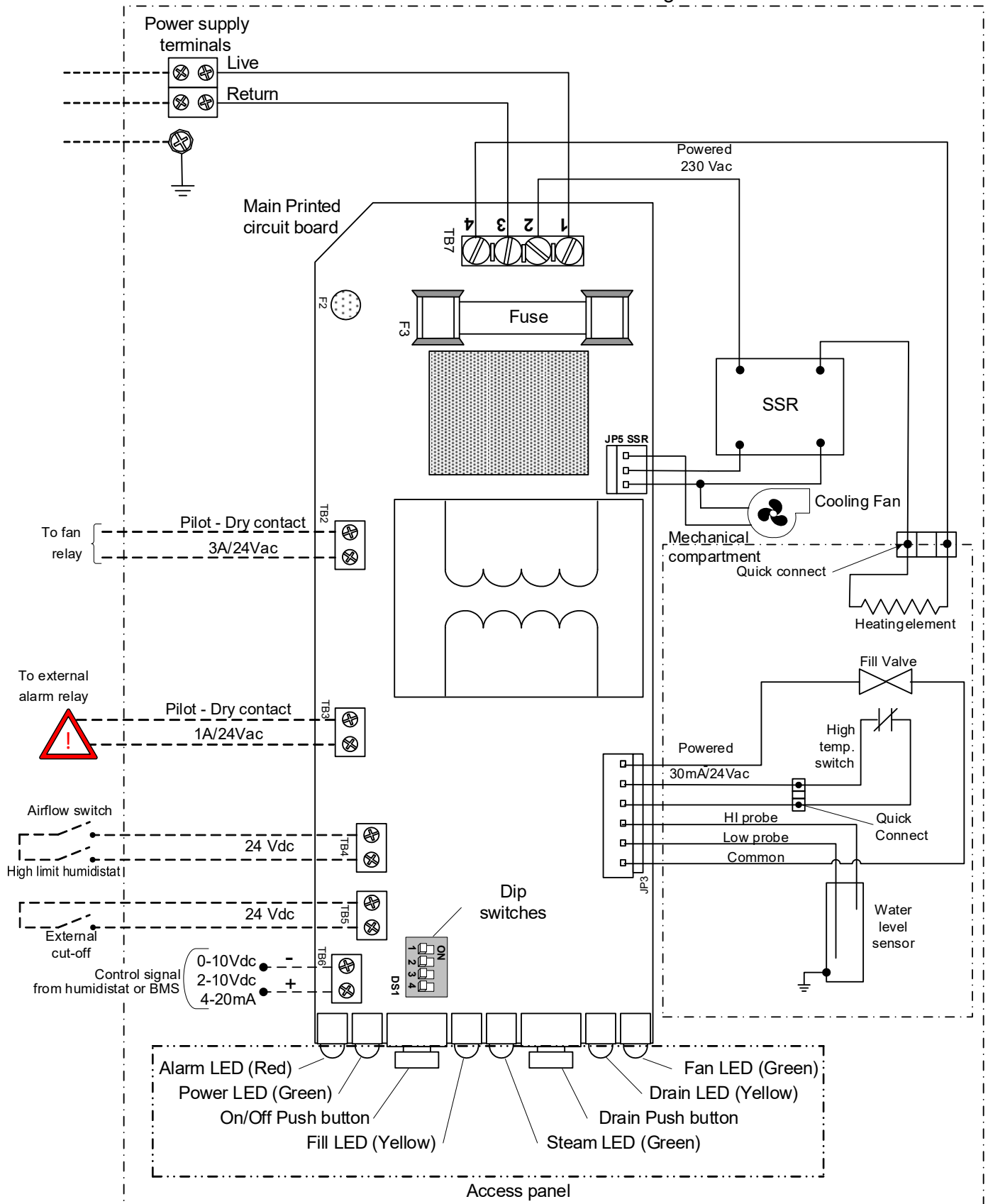

(Fig. 17b)

18.3. Modulating humidifier with HRO20

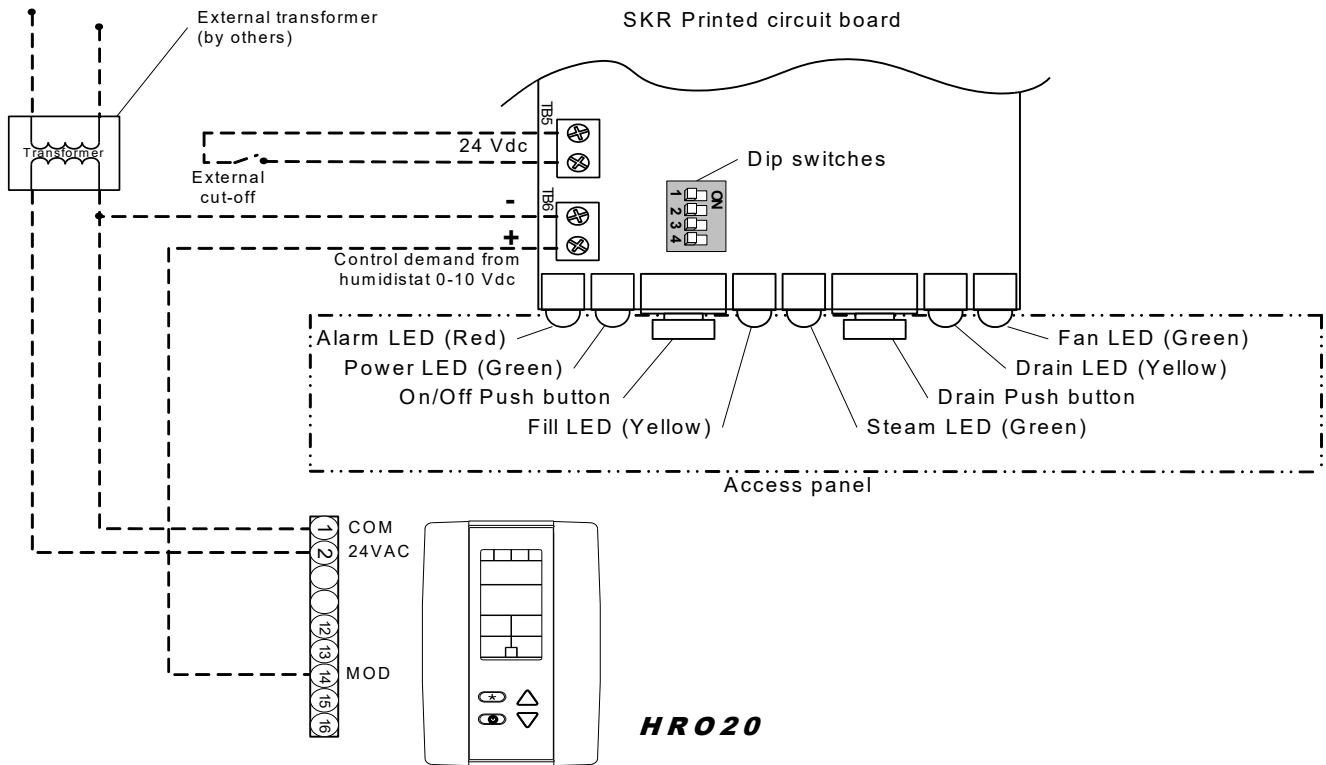

(Fig. 17c)

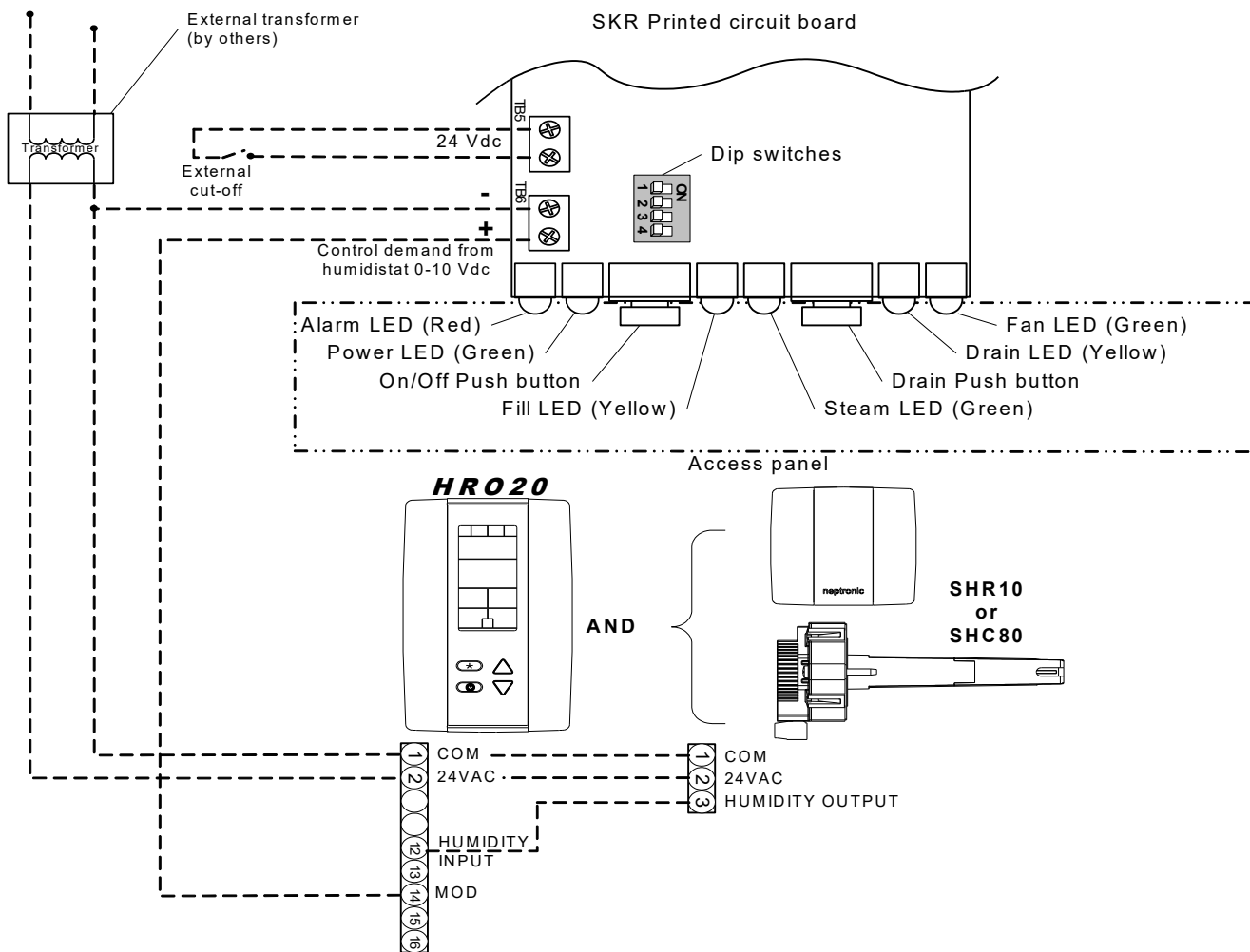
18.4. Modulating humidifier with HRO20 and SHR10 or SHC80

(Fig. 17d)



neptronic®

400 Lebeau blvd, Montreal, Qc, H4N 1R6, Canada

www.neptronic.com

Toll free in North America: 1-800-361-2308

Tel.: (514) 333-1433

Fax: (514) 333-3163

Customer service fax: (514) 333-1091

Monday to Friday: 8:00am to 5:00pm (Eastern time)